

Ovens & Furnaces up to 3000°C

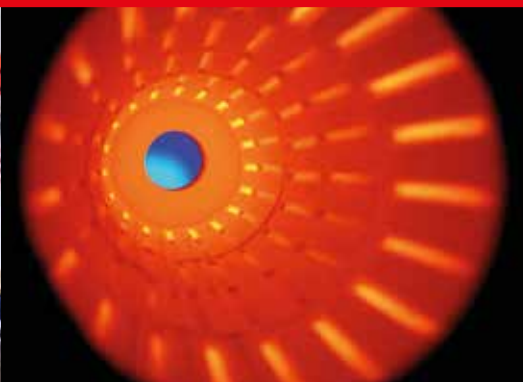



Leading Heat Technology

Innovative from the start in Sheffield in 1938 Carbolite took its name from the silicon carbide elements that were at the heart of its new high temperature combustion furnaces. Continuing to grow, in 1956 the privately owned business became incorporated as a limited company and in the intervening years Carbolite has become the UK's largest manufacturer of standard laboratory and bespoke industrial furnaces and ovens exporting to over 100 countries worldwide.

Carbolite recently acquired Gero Hochtemperaturöfen GmbH & Co. KG, a manufacturer of industrial furnaces based in Neuhausen near Stuttgart in southern Germany. Gero has more than 30 years of professional heat treatment experience with standard products and customer-specific solutions. Carbolite, together with Gero, is part of the Verder Scientific Division which includes Eltra, Retsch and Retsch Technology.

Operating from a modern manufacturing plant and sales office in the heart of the Peak District National Park, Carbolite has established a reputation for engineering expertise that is founded upon many years' experience in applied heating technology.

Continuous product development and longstanding, interactive relationships with suppliers enable us to incorporate the latest technologies into our products, keeping us at the forefront in furnace and oven design.

Standard chamber designs are available from 3 to 14,000 litres and can be supplied with many load handling

options. The products encompass a temperature range from 20 – 1800 °C. This portfolio is enhanced by Gero products with furnaces up to 3000 °C and a large variety of solutions for vacuum and other modified atmospheres.

Temperature control options range from simple setpoint controllers, to sophisticated multiple zone, cascade and programmable temperature control systems.

Carbolite's flexibility and ability to solve customers' individual application requirements have given its products an important place in aerospace, engineering, materials science, heat treatment, medical, bioscience and contract testing laboratories around the world to name just a few.

Carbolite not only regularly supplies products with standards compliant furnace and oven designs, such as for Nadcap (AMS2750E) heat treatment processes, but can also supply fully traceable certification for control, measurement, recording and data acquisition devices, issued by an independent UKAS accredited laboratory.

All the products featured in this catalogue, and more, are available through an extensive worldwide network of dealers and local offices. Factory trained field engineers provide a complete range of after sales support and technical advice. Guidance on product selection is available from a team of qualified engineers based at Hope or via our international distributor network.

www.carbolite.com



Products in this section include both laboratory and industrial ovens with maximum operating temperatures up to 750°C. Application specific equipment includes the Asphalt Binder Analyser (ABA) for the determination of binder content in asphalt.

Ovens Selection Guide		08
Universal Laboratory Ovens		
Laboratory Bench Mounted Ovens	AX	10
Natural Convection Ovens	PN	11
Fan Convection Ovens	PF	12
High Temperature Ovens		
High Temperature Bench Mounted Ovens	LHT	13
High Temperature Industrial Ovens	HT	14
Modified Atmosphere Ovens	HTMA	15
Application Specific Ovens		
Asphalt Binder Analyser	ABA	16
Rapid Cooling Ovens	TLD	18
Clean Room Ovens		
Clean Room Ovens to 250°C	CR	19
High Temperature Clean Room Ovens	HTCR	20
Industrial Batch Ovens		
Air Recirculating Ovens	HRF	22
General Purpose Ovens	GP	23
Large General Purpose Ovens	LGP	24

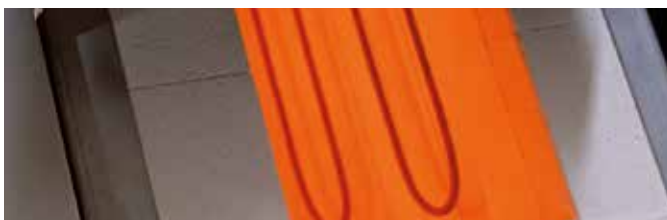

Products in this section include an extensive range of chamber and tube furnaces with maximum operating temperatures up to 1300°C. The range of tube furnaces includes horizontal and vertical, single and 3-zone models as well as models specifically for use under vacuum and a tube furnace for carbon-14 and tritium analysis.

Chamber Furnaces Selection Guide		28
Universal Chamber Furnaces		
Economy Chamber Furnaces	ELF	30
Standard Chamber Furnaces	CWF	31
Rapid Heating Chamber Furnaces	RWF	32
Top Loading Chamber Furnaces	VCF	33
Ashing Furnaces Selection Guide		
Ashing Chamber Furnaces		
Standard Ashing Furnaces	AAF	34
Specialist Ashing Furnace	GSM	35
Burn-off Furnaces	BWF	36
Afterburner Ashing Furnace	ABF	37
Tube Furnaces Selection Guide		
Universal Tube Furnaces		
Small Tube Furnaces	MTF	40
Large Tube Furnaces	CTF 12	41
Compact Modular Tube Furnaces	EHA, EVA, EST, EVT	42
Horizontal Split Tube Furnaces	HST	44
Vertical Split Tube Furnaces	VST 12	45
Modular Horizontal Tube Furnaces	GHA	46
Modular Vertical Tube Furnaces	GVA	47
Rotary Reactor Tube Furnaces	HTR	48
Three Zone Tube Furnaces		
Standard 3-Zone Tube Furnaces	TZF	49
Compact Modular 3-Zone Tube Furnaces	EHC, EVC, EZS, EVZ	50
Horizontal Split 3-Zone Tube Furnaces	HZS	52
Vertical Split 3-Zone Tube Furnaces	TVS	53
Modular Horizontal 3-Zone Tube Furnaces	GHC	54
Modular Vertical 3-Zone Tube Furnaces	GVC	55
Application Specific Furnaces		
Carbon-14 and Tritium Furnaces	MTT	56
High Vacuum Tube Furnaces	HVTT	57
Thermocouple Calibration Furnaces	PTC	58
Cupellation Furnaces	CF	59
Industrial Batch Furnaces		
General Purpose Chamber Furnaces	GPC	60
Large Chamber Furnaces	LCF	61

Disclaimer

As Carbolite has a policy of continuous product development, improvements and changes will be made during the lifetime of this catalogue. Carbolite reserves the right to amend the specifications at any time and in any particular way without prior notice provided that the ultimate performance of the equipment is not reduced by such action.

If the dimensions or technical specification of a product in this catalogue are critical, it is important that Carbolite is contacted to confirm the details prior to order placement.



Products in this section include an extensive range of chamber and tube furnaces with maximum operating temperatures up to 1800°C. Specialist models include bottom loading furnaces.

Chamber Furnaces Selection Guide		28
Universal Chamber Furnaces		
High Temperature Chamber Furnaces	RHF	64
High Temperature Laboratory Chamber Furnaces	HTF	66
High Temperature Bottom Loading Furnaces	BLF	67
Tube Furnaces Selection Guide		38
Universal Tube Furnaces		
High Temperature Single Zone Tube Furnaces	STF	68
High Temperature Vertical Single Zone Split Tube Furnaces	VST 17	70
High Temperature Horizontal Tube Furnaces	CTF 17 & 18	71
High Temperature 3-Zone Tube Furnaces	TZF	72
Application Specific Furnaces		
High Vacuum Tube Furnaces	HVTT	73
Dental Furnace	CDF	74
Smelting Furnaces	SCF	75

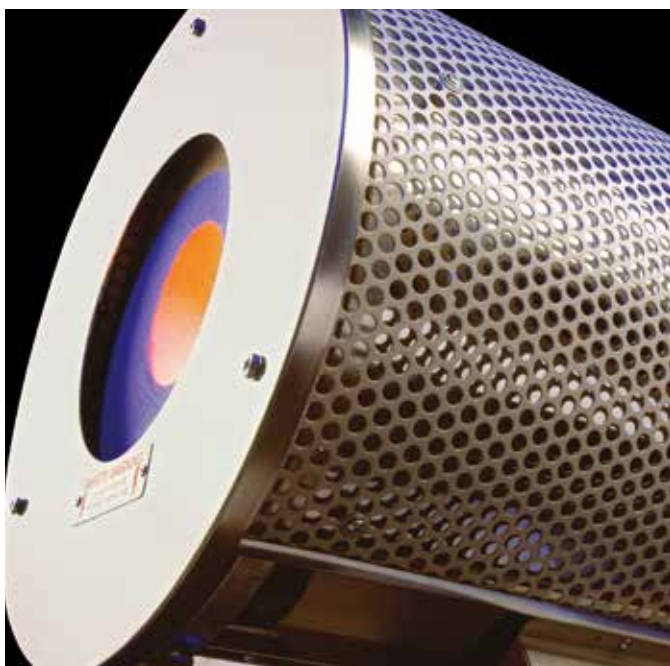

As a part of Carbolite, the product range of Gero enhances the portfolio with furnaces up to 3000°C and a large variety of solutions for vacuum and other modified atmospheres. Only a small range of the products is included. For more information, separate product brochures are available.

Furnaces up to 3000°C (Gero Products)	78
--	----

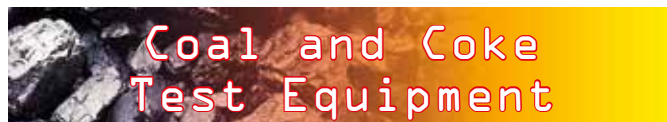

Information on laboratory and pilot scale equipment for coal, coke and iron ore testing can be found in this section. These products are also described in a separate brochure.

Coal and Coke Test Equipment	80
-------------------------------------	----



This section demonstrates Carbolite's expertise in designing and building equipment to meet specific customer requirements. Some examples are given. For further information please enquire at info@carbolite.com.

Custom Built Equipment	84
-------------------------------	----

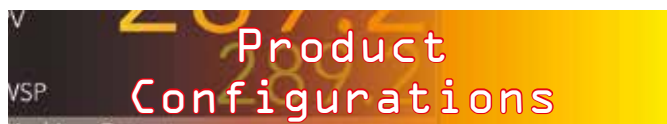

All Carbolite products are fitted with a controller from a sophisticated range of temperature controllers and optional data loggers. Tube furnaces often require additional work tubes and accessories for use with modified atmosphere and vacuum. Chamber furnaces can also be used with modified atmosphere by fitting a retort. Detailed information on these options as well as power supply information can be found on the following pages.

Product Configurations	
Temperature Control Options	88
Work Tube Selection Guide	92
Work Tube Accessories	94
Modified Atmosphere Options	95

Power Supply Information	96
---------------------------------	----

Index	98
--------------	----

Products in this section include both laboratory and industrial ovens with maximum operating temperatures up to 750 °C. Application specific equipment includes the Asphalt Binder Analyser (ABA) for the determination of binder content in asphalt.

20 °C - 750 °C



Temperature Range 20 °C – 750 °C	Models	Page
Ovens Selection Guide		08
Universal Laboratory Ovens	AX, PN, PF	10
High Temperature Ovens	LHT, HT, HTMA	13
Application Specific Ovens	ABA, TLD	16
Clean Room Ovens	CR, HPCR	19
Industrial Batch Ovens	HRF, GP, LGP	22
Product Configurations		88

Carbolite determines ovens as operating up to 700 °C, where heat transfer is predominantly by convection (as shown right).

However, also included are the LGP range of large industrial ovens with a maximum temperature of 700 °C and the HRF range of air recirculating ovens at 750 °C.

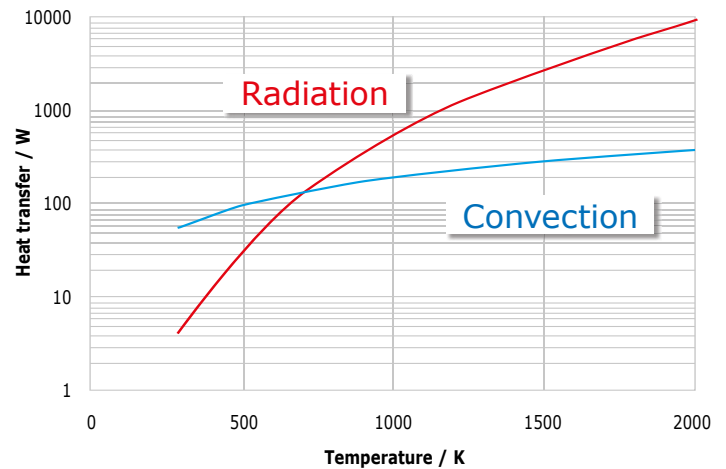

The selection of an oven should take into account the following factors:

What temperature?

- Carbolite offers several ranges of ovens with different maximum operating temperatures. The Apex (AX) range has maximum temperature of 250 °C and the Peak (PF/PN) range has a maximum operating temperature of 250 °C, or 300 °C, depending on the model. These ranges have a minimum working temperature of ambient +30 °C.
- The range of higher temperature ovens has a working range of ambient +60 °C to maximum operating temperatures of 400 °C, 500 °C, 600 °C and 700 °C.
- Ovens are suitable for use at their maximum operating temperature.

What size?

- Carbolite's smallest bench mounted oven has a capacity of 30 litres, but larger standard volume ovens up to 14,000 litres are available.
- The uniform volume of an oven is not the total internal volume; it is smaller than the total volume due to the heat losses through the walls and door.
- Depending on the model, it may be possible to add shelves or change the shelving spacing to increase the capacity, or to suit different size work pieces.

Natural or fan convection?

- Simple ovens do not have a fan fitted, but have elements mounted in the chamber base. Air circulates by convection; the warmed air at the base initially rises then falls as it cools. The resulting slow airflow is preferable, for example, for processes involving powders which may be disturbed by fan convection or where there is a risk of cross contamination between samples.
- In fan convection ovens the elements are located on the side of the oven and on smaller ovens the fan blows air through an air-guide, over the heating elements and around the chamber. On larger ovens, where there is room for a more complex air guide, the fan pulls air over the elements. The fan action thoroughly mixes the heated air, equalising its temperature before blowing it around the chamber and over the sample.

Advantages of fan convection

- The oven heats up and recovers the temperature more quickly
- The higher airflow improves the contact between the sample/load and as a result the sample/load also heats up faster
- The airflow conveys the heat to the temperature sensor more quickly, resulting in improved control stability
- The temperature uniformity is improved
- The fan promotes higher airflow in and out of the chamber and speeds up drying by faster removal of vapour (water or solvents – see additional note regarding the use of solvents in ovens)
- Variable speed fans are also offered which can be a solution to the problem of disturbing the samples/ cross contamination

Exhaust options

Exhaust fan – an extraction unit is fitted to the oven and is provided with an on/off switch. Suitable for use in applications creating large amounts of fumes which need to be extracted from the oven.

Moisture extraction (MEO) – this option makes the oven suitable for drying processes which contain a lot of moisture. It includes the air exhaust fan option, plus the addition of sealing the chamber seams to prevent moisture from entering the insulation.



Stoving and curing – designed for use with paints, resins and solvents, this option can remove small quantities of volatile solvents from the chamber. It includes the air exhaust fan and sealing of the chamber seams. An airflow failure sensor cuts heating if the exhaust system is not working effectively. An explosion relief panel is also added: a section of the chamber lining and the outer case are replaced with a lightweight thermal insulation panel which is covered with aluminium foil; in the event of an explosion this panel is harmlessly pushed out of the oven to release the pressure. Electronic over-temperature protection is fitted as standard with this option. The fitting of the stoving and curing option enables ovens to meet the requirements of BS EN 1539 : 2009 'Dryers and ovens, in which flammable substances are released – safety requirements'.

Please note: this option is suitable for small amounts of solvent only – please consult Carbolite regarding your application before ordering this option.

Specific application ovens

Clean room ovens

Carbolite manufactures clean room ovens, including high temperature models to 600 °C, to operate in the following clean room environments (see pages 19-21).

Standard	Classification			
ISO 14644-1	5	6	7	8
BS 5295	E/F	G/H	J	K
Federal standard 209E	100	1000	10,000	100,000

HTMA ovens (high temperature modified atmosphere)

The design and construction of these ovens ensures a high temperature oven suitable for use with inert atmospheres and designed for use in a batch production environment. Oxygen levels down to 50 ppm are achievable in the chamber (see page 15).

TLD oven (thermo-luminescent dosimeter)

Originally designed for annealing thermo-luminescent dosimeters, these ovens are also ideal for applications such as tempering, glass annealing, preheating and stress relieving (see page 18).

Asphalt Binder Analyser (ABA 7/35B)

A high temperature oven designed to simultaneously burn off and measure the asphalt binder content by loss on ignition (see pages 16-17).

Custom designed ovens

In addition to the extensive range of standard ovens, Carbolite also offers a custom design and build service. Simple modifications can be accommodated, as well as the manufacture of large special units for use in compliance with standards such as Nadcap AMS 2750E for the aerospace industry.

Universal Laboratory Ovens

10

AX – Laboratory Bench Mounted Ovens

The Apex AX series ovens is a range of 250 °C laboratory ovens, comprising three bench mounted models equipped with the R38 digital PID temperature controller.



AX 60



AX 30

Standard features

- 250 °C maximum operating temperature
- 30, 60 or 120 litre chamber volumes
- Equipped with the R38 digital PID temperature controller
- Fan convection for rapid heating & excellent uniformity
- Chemically resistant stainless steel liner
- Two adjustable nickel-chrome plated wire shelves
- Lever latch door & airtight silicone seal
- Built to comply with BS EN 61010-2-010:2003

Options (specify these at time of order)

- Over-temperature protection (recommended to protect valuable contents & for unattended operation)
- Digital countdown timer to switch oven off
- Additional sets of shelves & runners
- Lockable door
- Low voltage options for use below 220 V
- Routine spares kit

Technical data

Model	Max temp (°C)	Temp uniformity (°C)	Heat-up time (mins)	Recovery time (mins)	Dimensions: Internal H x W x D (mm)	Dimensions: External H x W x D (mm)	Shelves fitted / accepted	Shelf loading each / total (kg)	Volume (litres)	Air changes / hr	Max power (W)	Holding power (W)	Weight (kg)
AX 30	250	±5.0 @ 250 °C	23	3	295 x 300 x 320	440 x 590 x 465	2 / 4	10 / 20	28	65	1000	320	24
AX 60	250	±5.0 @ 250 °C	25	3	395 x 400 x 420	540 x 690 x 565	2 / 6	10 / 30	66	28	1500	475	37
AX 120	250	±5.0 @ 250 °C	26	3	495 x 500 x 520	640 x 790 x 665	2 / 8	10 / 40	128	14	2000	650	55

i Please note:

- Minimum operating temperature approximately ambient plus 30 °C
- Uniformity is measured in an empty chamber with vents closed, after a stabilisation period
- Maximum power and heat up time based on a 240 V supply

- Shelf loadings are based on evenly distributed weight
- The uniform volume is smaller than the total chamber volume

The Peak series 300°C laboratory ovens are available in both PN natural convection and in the PF fan convection models. All PN models are bench mounted.

In the PN ovens air circulation depends upon natural convection. The resulting slow airflow is preferable, for example, for processes involving powders which may be disturbed by fan convection or where there is a risk of cross contamination between samples. The reduced complexity makes natural convection a less expensive option.

Standard features

- Economical natural convection models
- 300°C maximum operating temperature
- R38 PID controller
- Chemically resistant stainless steel liner
- Two nickel-chrome plated wire shelves
- Lever latch door & airtight silicone seal
- Compliant with safety standard BS EN 61010-2-010:2003



PN 60

Options (specify these at time of order)

- Over-temperature protection (recommended to protect valuable contents & for unattended operation)
- A range of sophisticated digital controllers, multi-segment programmers and data loggers is available. These can be fitted with RS232, RS485 or Ethernet communications (see pages 88-91)
- Access port for independent thermocouple
- Accessory shelves & runners
- Cable access ports
- Viewing window
- Interior light
- Stacking frame
- Lockable door
- Door switch to isolate elements
- Floor stands & wheeled trolleys
- Routine spares kit

Technical data

Model	Max temp (°C)	Temp stability (°C)	Temp uniformity (°C)	Heat-up time (mins)	Recovery time (mins)	Dimensions: Internal H x W x D (mm)	Dimensions: External H x W x D (mm)	Shelves fitted / accepted	Shelf loading each / total (kg)	Volume (litres)	Max power (W)	Holding power (W)	Weight (kg)
PN 30	300	±0.5	±7.0 @ 300°C	52	8.5	255 x 330 x 320	470 x 665 x 470	2 / 3	10 / 20	27	750	300	30
PN 60	300	±0.5	±7.0 @ 300°C	52	8.5	350 x 392 x 420	570 x 765 x 570	2 / 5	10 / 30	57	1000	480	45
PN 120	300	±0.5	±7.0 @ 300°C	52	8.5	450 x 492 x 520	670 x 865 x 670	2 / 9	10 / 40	115	1500	720	60
PN 200	300	±0.5	±7.0 @ 300°C	58	10	700 x 592 x 520	920 x 965 x 670	2 / 15	10 / 50	215	2250	1160	75

i Please note:

- Minimum operating temperature approximately ambient plus 30°C
- Uniformity is measured in an empty chamber with vents closed, after a stabilisation period
- Maximum power and heat up time based on a 240 V supply

- Shelf loadings are based on evenly distributed weight
- Temperature uniformity is smaller than the total chamber volume

The Peak series 300 °C laboratory ovens are available as both PF fan convection and PN natural convection models.

Fan convection provides greater temperature uniformity and faster recovery rates than natural convection.

Standard features

- 300 °C maximum operating temperatures
- 28 to 230 litre chamber volumes
- Precision PID control & display using the R38 controller
- Fan convection for rapid heating & recovery & excellent uniformity
- Chemically resistant stainless steel liner
- Two nickel-chrome plated wire shelves
- Lever latch door & airtight silicone seal
- Compliant with safety standard BS EN 61010-2-010:2003

Options (specify these at time of order)

- Over-temperature protection (recommended to protect valuable contents & for unattended operation)
- A range of sophisticated digital controllers, multi-segment programmers and data loggers is available. These can be fitted with RS232, RS485 or Ethernet communications (see pages 88-91)
- Top access port for independent thermocouple



PF 200

- Accessory shelves & runners
- Cable entry port
- Variable speed fan control
- Stoving & curing options for extraction of small volumes of volatile solvents (not compatible with viewing window option)
- Viewing window (not compatible with stoving & curing option)
- Interior light (not compatible with stoving & curing option)
- Air exhaust fan
- Moisture extraction option (comprising sealed seams and air exhaust fan)
- Stacking frame to enable units to be stacked one upon another
- Lockable door
- Door switch to isolate elements and fan
- Fixed or castor mounted floor stands
- Low voltage options for use below 220 V
- Routine spares kit

Technical data

Model	Max temp (°C)	Temp stability (°C)	Temp uniformity (°C)	Heat-up time (mins)	Recovery time (mins)	Dimensions: Internal H x W x D (mm)	Dimensions: External H x W x D (mm)	Shelves fitted / accepted	Shelf loading each / total (kg)	Volume (litres)	Air changes / hr	Max power (W)	Holding power (W)	Weight (kg)
PF 30	300	±0.2	±5.0 @ 300°C	25	4	300 x 290 x 320	470 x 665 x 470 (Bench-top)	2 / 3	10 / 20	28	50 / 360*	750	300	30
PF 60	300	±0.2	±5.0 @ 300°C	25	4	400 x 390 x 420	570 x 765 x 570 (Bench-top)	2 / 5	10 / 30	66	21 / 153*	1000	480	45
PF 120	300	±0.2	±5.0 @ 300°C	25	4	500 x 490 x 520	670 x 865 x 670 (Bench-top)	2 / 9	10 / 40	127	11 / 79*	1500	720	60
PF 200	300	±0.2	±5.0 @ 300°C	30	5	750 x 590 x 520	920 x 965 x 670 (Bench-top)	2 / 15	10 / 50	230	6 / 44*	2250	1160	75

i Please note:

- Minimum operating temperature approximately ambient plus 30 °C
- Uniformity is measured in an empty chamber with vents closed, after a stabilisation period
- Maximum power and heat up time based on a 240 V supply

- The uniform volume is smaller than the total chamber volume
- Shelf loadings are based on evenly distributed weight
- *When equipped with optional exhaust fan

The LHT laboratory high temperature ovens comprise 3 sizes of bench mounted ovens, each available with maximum operating temperatures of 400 °C, 500 °C and 600 °C.

Standard features

- 400 °C, 500 °C or 600 °C operating temperatures
- 30, 60 & 120 litre capacities
- R38 PID controller
- Heavy duty convection fan for good uniformity
- Low thermal mass insulation for fast response & energy efficiency
- Corrosion resistant, brushed stainless steel interior
- 2 Multi-position shelves
- Suitable for continuous operation
- Hard wearing, zinc coated & stoved epoxy polyester coated exterior



LHT 6/30

Options (specify these at time of order)

- Cable entry ports
- Over-temperature protection (recommended to protect valuable contents & for unattended operation)
- A range of sophisticated digital controllers, multi-segment programmers and data loggers is available. These can be fitted with RS232, RS485 or Ethernet communications (see pages 88-91)
- Viewing window (not compatible with stoving & curing option)
- Stoving & curing options for extraction of small volumes of volatile solvents (not compatible with viewing window option)
- Variable speed fan
- Floor stands & stacking frames
- Routine spares kit
- Air exhaust fan (may alter achievable uniformity)

Technical data

Model	Max temp (°C)	Temp stability (°C)	Temp uniformity (°C)	Heat-up time (mins)	Recovery time (mins)	Dimensions: Internal H x W x D (mm)	Dimensions: External H x W x D (mm)	Shelves fitted / accepted	Volume (litres)	Max power (W)	Weight (kg)
LHT 4/30	400	±0.5	±5.0 @ 250°C	50	10	300 x 300 x 305	570 x 860 x 550	2	30	1000	73
LHT 4/60	400	±0.5	±5.0 @ 250°C	-	16	400 x 400 x 405	670 x 930 x 670	2 / 3	60	1500	99
LHT 4/120	400	±0.5	±5.0 @ 250°C	-	20	645 x 455 x 405	920 x 1060 x 650	2 / 4	120	2250	179
LHT 5/30	500	±0.5	±5.0 @ 250°C	-	10	300 x 300 x 305	570 x 860 x 550	2	30	2000	73
LHT 5/60	500	±0.5	±5.0 @ 250°C	50	16	400 x 400 x 405	670 x 930 x 670	2 / 3	60	2250	99
LHT 5/120	500	±0.5	±5.0 @ 250°C	-	20	645 x 455 x 405	920 x 1060 x 650	2 / 4	120	3000	179
LHT 6/30	600	±0.5	±5.0 @ 250°C	70	10	300 x 300 x 305	570 x 860 x 550	2	30	2000	73
LHT 6/60	600	±0.5	±5.0 @ 250°C	-	10*	400 x 400 x 405	670 x 930 x 670	2 / 3	60	2250	99
LHT 6/120	600	±0.5	±5.0 @ 250°C	-	-	645 x 455 x 405	920 x 1060 x 650	2 / 4	120	3000	179

i Please note:

- Minimum operating temperature approximately ambient plus 60 °C
- *Recovery to 500 °C setpoint
- The uniform volume is smaller than the total chamber volume

- Stoving and curing option will reduce achievable temperature uniformity
- Maximum power and heat up time based on a 240 V supply

High Temperature Ovens

14

HT – High Temperature Industrial Ovens

The HT high temperature ovens are manufactured in 4 standard chamber sizes with maximum operating temperatures of 400 °C, 500 °C and 600 °C. Their robust construction incorporates heavy duty hinges, door catches and shelving systems.

This range also provides a foundation upon which a wide range of custom modifications can be added. Typical examples of which are the more sophisticated control systems and data recording that is required for applications such as AMS 2750E heat treatment under Nadcap, or modifications to handle heavier loads or assist in loading and unloading the oven, or simply larger chamber sizes than are offered in the standard range.



HT 6/220

Standard features

- 400 °C, 500 °C or 600 °C maximum operating temperatures
- 28, 95, 220 or 350 litre capacity
- Carbolite 301 controller providing single ramp to set point
- Robust construction
- Excellent performance & reliability
- Stainless steel liner
- Stainless steel perforated shelves

Options (specify these at time of order)

- Over-temperature protection (recommended to protect valuable contents & for unattended operation)
- A range of sophisticated digital controllers, multi-segment programmers and data loggers is available. These can be fitted with RS232, RS485 or Ethernet communications (see pages 88-91)
- Additional shelves
- Viewing window (not compatible with stoving and curing option)
- Stoving & curing options for extraction of small volumes of volatile solvents (not compatible with viewing window option)

Technical data

Model	Max temp (°C)	Temp stability (°C)	Temp uniformity (°C)	Heat-up time (mins)	Recovery time (mins)	Dimensions: Internal H x W x D (mm)	Dimensions: External H x W x D (mm)	Shelves fitted / accepted	Shelf loading each / total (kg)	Volume (litres)	Max power (W)
HT 4/28	400	±0.5	±5.0	60	10	305 x 305 x 305	880 x 675 x 885	2 / 2	10 / 20	28	1000
HT 4/95	400	±0.5	±5.0	60	10	455 x 455 x 455	1010 x 880 x 1120	3 / 4	15 / 30	94	3000
HT 4/220	400	±0.5	±5.0	60	10	610 x 610 x 610	1160 x 1030 x 1280	3 / 4	25 / 50	227	4500
HT 4/350	400	±0.5	±5.0	-	-	700 x 700 x 700	1665 x 1710 x 1200	3 / 4	25 / 50	343	-
HT 5/28	500	±0.5	±5.0	60	16	305 x 305 x 305	880 x 675 x 885	2 / 2	10 / 20	28	2000
HT 5/95	500	±0.5	±5.0	60	16	455 x 455 x 455	1010 x 880 x 1120	3 / 4	15 / 30	94	3000
HT 5/220	500	±0.5	±5.0	60	16	610 x 610 x 610	1160 x 1030 x 1280	3 / 4	25 / 50	227	4500
HT 5/350	500	±0.5	±5.0	-	-	700 x 700 x 700	1665 x 1710 x 1200	3 / 4	25 / 50	343	-
HT 6/28	600	±0.5	±5.0	75	20	305 x 305 x 305	880 x 675 x 885	2 / 2	10 / 20	28	2000
HT 6/95	600	±0.5	±5.0	70	20	455 x 455 x 455	1010 x 880 x 1120	3 / 4	15 / 30	94	4500
HT 6/220	600	±0.5	±5.0	90	20	610 x 610 x 610	1160 x 1030 x 1280	3 / 4	25 / 50	227	6000
HT 6/350	600	±0.5	±5.0	-	-	700 x 700 x 700	1665 x 1710 x 1200	3 / 4	25 / 50	343	9000

i Please note:

- Minimum operating temperature approximately ambient plus 60 °C
- Uniformity is measured in an empty chamber with vents closed, after a stabilisation period
- Maximum power and heat up time based on a 240 V supply

- Shelf loadings are based on evenly distributed weight
- The uniform volume is smaller than the total chamber volume

The HTMA series is a range of modified atmosphere high temperature ovens for use with inert atmospheres.

Separate flow controls for purge and process gases mean that once the chamber has been purged of atmospheric air process gas can be used with lower flow rates. Switching between purge and process gases can either be done manually or by adding the option of an automatic programmable control system. Oxygen levels down to 50 ppm are achievable.

Standard features

- 400 °C, 500 °C or 600 °C operating temperatures
- 28, 95 & 220 litre capacities
- Carbolite 301 PID controller with single ramp to setpoint and including over-temperature protection
- Rear mounted fan & side air guides give horizontal 'airflow'
- Fully seam welded to contain modified atmosphere
- Manual gas control via needle valves & flowmeters (nickel brass)
- Corrosion resistant stainless steel interior with perforated shelves & runners
- Stainless steel pipe-work, nickel brass flow-meter & solenoid valves
- Single side hinged door, with metal heat seal & rubber gas tight seal, closed using non slam lever handle
- Hard wearing, zinc coated & stoved epoxy polyester coated exterior



HTMA 6/28

Options (specify these at time of order)

- Automatic gas control (requires a 3508 series programmable controller)
- A range of sophisticated digital controllers, multi-segment programmers and data loggers is available. These can be fitted with RS232, RS485 or Ethernet communications (see pages 88-91)
- Stainless steel flow-meter & solenoid valves, instead of nickel brass
- Fixed or castor mounted floor stands
- Flow failure alarm
- 700 °C model available (see page 84)

Technical data

Model	Max temp (°C)	Heat-up time (mins)	Recovery time (mins)	Dimensions: Internal H x W x D (mm)	Dimensions: External H x W x D (mm)	Shelves fitted / accepted	Volume (litres)	Max power (W)	Weight (kg)
HTMA 4/28	400	50	10	305 x 305 x 305	880 x 675 x 885	2 / 2	28	1000	73
HTMA 4/95	400	75	16	455 x 455 x 455	1010 x 880 x 1120	3 / 4	95	3000	99
HTMA 4/220	400	120	20	610 x 610 x 610	1160 x 1030 x 1280	3 / 4	220	3000	179
HTMA 5/28	500	50	10	305 x 305 x 305	880 x 675 x 885	2 / 2	28	2000	73
HTMA 5/95	500	75	16	455 x 455 x 455	1010 x 880 x 1120	3 / 4	95	3000	99
HTMA 5/220	500	120	20	610 x 610 x 610	1160 x 1030 x 1280	3 / 4	220	4500	179
HTMA 6/28	600	50*	10*	305 x 305 x 305	880 x 675 x 885	2 / 2	28	2000	73
HTMA 6/95	600	75*	16*	455 x 455 x 455	1010 x 880 x 1120	3 / 4	95	4500	99
HTMA 6/220	600	120*	20*	610 x 610 x 610	1160 x 1030 x 1280	3 / 4	220	6000	179

i Please note:

- Minimum operating temperature approximately ambient plus 60°C
 - Uniformity is measured in an empty chamber with vents closed, after a stabilisation period

- Maximum power and heat up time based on a 240 V supply
 - *Nominal values based upon a representative sample of products

The ABA 7/35B is designed to measure the asphalt binder content of hot mix asphalt as well as warm mix asphalt using loss on ignition, in accordance with AASHTO T 308-10, ASTM D6307-10 & BS/EN 12697-39:2012.

The integral microprocessor driven weighing and calculation system is flexible enough to handle local variations upon the standard test method. Test result reports are available in both printed and software format. The high temperature afterburner minimises the production of noxious fumes. Supplied complete with 2 sets of sample baskets

Standard features

- Designed to measure asphalt binder content by loss on ignition
- Avoids the health, environmental & waste management issues & expense associated with the older solvent extraction methods
- Reduced emissions due to high temperature afterburner
- Controlled via a multi-lingual touchscreen interface
- Supplied as standard with English, Spanish, French, Chinese, Italian & Russian language display & other languages available to order
- Automatic calculation of final sample weight & binder % result
- Adjustable aggregate correction factor
- Precise weight measurements displayed to 0.1 g resolution
- Has the capacity for large sample sizes for more accurate results (maximum sample is 4.5 kg)
- Average test times from 20 mins for 6 mm aggregates, to 45 mins for 40 mm aggregates
- Permanent (dot-matrix) printed reports with user configured timing
- USB data output compatible with most spread sheets
- Easy naming, storage & recall of recipes that can be easily transferred between ovens
- Simplified menu structure with secure 'Supervisor' & 'Operator' settings



- 1 Integral fan assisted high-temperature afterburner greatly reduces emissions
- 2 Safety circuits warning lamps
- 3 Rapid heating main chamber with robust wire elements
- 4 Integral balance measures loss on ignition to 0.1 g resolution
- 5 Automatic capture of weight data is possible from external balances
- 6 Optional flat pack floor stand
- 7 Control panel with:
 - Printer on/off switch
 - Safety circuits test switch
 - Oven on/off switch
 - Afterburner heating lamp
 - Main chamber heater lamps
 - USB data output
- 8 Printer

Safe robust design

- Failsafe door interlock keeps the door locked during a test even in the event of a power failure, protecting the operator from the burning test sample
- Electrical supply is isolated from the heating elements when the door is opened
- Afterburner temperature is controlled independently from the main chamber
- Automatic capture and calculation of values minimises human errors
- Double skin construction gives safe external surfaces
- Corrosion resistant, stoved epoxy finish for a long working life
- Rapid heat up rate enables the ABA to be switched off between tests, reducing power consumption
- Low thermal mass insulation & efficient element designs means that the ABA is ready to use in approximately 30 minutes
- Internal balance is easily calibrated in position using a 5 kg standard calibration mass

Options (specify these at time of order)

- Factory fitted thermocouple access port
- 'Flat pack' floor stand
- Sample cooling stand
- Additional sample baskets
- Metal extraction pipe
- Touchscreen protection film
- Gloves
- Face shield



basket set & red cooling cage



sample cooling stand with personal protective equipment

Technical data

Model	Max temp (°C)	Dimensions: Internal H x W x D (mm)	Dimensions: External H x W x D (mm)	Max power (W)	Thermocouple type	Weight (kg)
ABA 7/35B	750	220 x 350 x 450	980 x 600 x 775 (Bench-top or optional stand)	8000	K	120

i Please note:

- The oven is rated at 8 kW for operation on 208/240 V, 50/60 Hz, three or single phase. Please state mains supply when ordering
- The oven holding power is approximately 3 kW

These ovens are frequently used for annealing thermo-luminescent dosimeters (TLD) that have been used to measure exposure to ionising radiation.

The TLD ovens are designed to heat to 400 °C, cooling rapidly to ambient temperature using forced air cooling. This rapid cycling capability is also suitable for other small scale tempering and annealing applications.



TLD/3

Standard features

- 400 °C maximum operating temperature
- 3508P1 programmable controller providing automatic activation of the cooling blower
- Horizontal forced air circulation from rear mounted fan
- Excellent performance & reliability
- Stainless steel liner
- Stainless steel mesh shelves

Options (specify these at time of order)

- Independent over-temperature protection with digital setpoint & display
- Digital process timer
- A range of sophisticated digital controllers, multi-segment programmers and data loggers is available. These can be fitted with RS232, RS485 or Ethernet communications (see pages 88-91)

Technical data

Model	Max temp (°C)	Temp stability (°C)	Temp uniformity (°C)	Heat-up time (mins)	Heating/cooling rate (°C/mins)	Dimensions: Internal H x W x D (mm)	Dimensions: External H x W x D (mm)	Shelves fitted / accepted	Volume (litres)	Max power (W)	Weight (kg)
TLD/3	400	±1	±5.0	60	4*	150 x 150 x 100	530 x 370 x 500	2 / 2	3	1000	26
TLD/28	400	±1	±5.0	60	4*	305 x 305 x 305	880 x 675 x 865	2 / 2	28	2250	95

i Please note:

- Minimum operating temperature approximately ambient plus 50 °C
- Uniformity is measured in an empty chamber with vents closed, after a stabilisation period
- Maximum power and heat up time based on a 240 V supply
- The uniform volume is smaller than the total chamber volume
- *Based upon cooling an empty chamber

The CR Series of 250°C clean room ovens comprises nine standard models in sizes from the 30 litre model to the 1790 litre model which, once processed through a customer's standard material entry regime, are suitable for operation within an ISO 14644-1 Class 5 environment*. All sources of particulate contamination are fully sealed. Their easily cleaned stainless steel interiors and gloss white epoxy exteriors prevent the shedding of particulate contamination.

*Federal Standard 209E Class 100 was superseded in 2001 by ISO 14644-1 Class 5



CR 70 & CR 30

Standard features

- 250°C maximum operating temperature
- 30 to 1790 litre chamber volumes
- Fully sealed low thermal mass insulation to avoid shedding fibres
- Fully enclosed brushless fan motor
- Carbolite 301 controller with single ramp to setpoint
- Perforated stainless steel shelves
- Particle free silicone rubber door seal
- Membrane control panel with clear bright LED display

Options (specify these at time of order)

- Over-temperature protection (recommended to protect valuable contents & for unattended operation)
- A range of sophisticated digital controllers, multi-segment programmers and data loggers is available. These can be fitted with RS232, RS485 or Ethernet communications (see pages 88-91)
- Top access port for independent thermocouple
- Cable access port
- Viewing window
- Frame to enable units to be stacked one upon another
- Lockable door
- Door switch to isolate elements and fan
- Fully customised through wall (flange fitted) designs are available

Technical data

Model	Max temp (°C)	Temp stability (°C)	Temp uniformity (°C)	Heat-up time (mins)	Recovery time (mins)	Dimensions: Internal H x W x D (mm)	Dimensions: External H x W x D (mm)	Shelves fitted / accepted	Shelf loading each / total (kg)	Volume (litres)	Max power (W)
CR/30	250	±0.2	±3.0 @ 250°C	35	4	310 x 310 x 310	685 x 460 x 670 (Bench-top or optional stand)	2 / 3	10 / 20	30	1000
CR/70	250	±0.2	±3.0 @ 250°C	35	4	310 x 470 x 470	685 x 620 x 820 (Bench-top or optional stand)	2 / 5	10 / 30	68	1500
CR/130	250	±0.2	±4.0 @ 250°C	35	4	550 x 470 x 470	925 x 620 x 820 (Bench-top or optional stand)	3 / 9	10 / 40	121	2000
CR/180	250	±0.2	±5.0 @ 250°C	58	5	770 x 470 x 470	1145 x 620 x 820 (Bench-top or optional stand)	3 / 15	10 / 50	170	2500
CR/220	250	±0.2	±5.0 @ 250°C	75	4	610 x 610 x 610	1360 x 940 x 970 (Bench-top or optional stand)	3 / 5	15 / 45	227	3000
CR/330	250	±0.2	±5.0 @ 250°C	80	6	915 x 610 x 610	1670 x 940 x 970 (Floor-standing or optional stand)	4 / 8	15 / 60	340	4500
CR/450	250	±0.3	±5.0 @ 250°C	75	9	1220 x 610 x 610	1930 x 940 x 970 (Floor-standing or optional stand)	5 / 11	15 / 75	450	6000
CR/840	250	±0.3	±5.0 @ 250°C	-	-	1525 x 915 x 610	2235 x 1395 x 970 (Floor-standing)	6	15 / -	850	12000
CR/1790	250	±0.3	±5.0 @ 250°C	-	-	1220 x 1220 x 1220	1930 x 1750 x 1580 (Floor-standing)	5	15 / -	1810	18000

i Please note:

- Minimum operating temperature approximately ambient plus 30°C
- Uniformity is measured in an empty chamber with vents closed, after a stabilisation period
- Maximum power and heat up time based on a 240 V supply

- Shelf loadings are based on evenly distributed weight
- The uniform volume is smaller than the overall chamber volume



HTCR 95 & 28 litre models

The HTCR Series of clean room ovens comprises fifteen standard models with five sizes between 28 and 1000 litres available with maximum temperatures of 400 °C, 500 °C and 600 °C.

Once processed through a customer's standard material entry regime HTCR Ovens are suitable for operation within an **ISO 14644-1 Class 6** environment*.

Optionally HTCR ovens can be supplied for operation within an **ISO 14644-1 Class 5** environment*.

*Federal Standard 209E Class 1000 was superseded in 2001 by ISO 14644-1 Class 6

*Federal Standard 209E Class 100 was superseded in 2001 by ISO 14644-1 Class 5

Standard features

- 400 °C, 500 °C or 600 °C maximum operating temperatures
- 28 to 1000 litre chamber volumes
- Fully sealed low thermal mass insulation avoids shedding fibres
- Fully enclosed brushless fan motor
- Carbolite 301 controller with single ramp to setpoint
- Smooth easily cleaned gloss epoxy exterior
- Polished stainless steel sealed interior
- Perforated stainless steel shelves
- Particle free silicone rubber door seal
- Membrane control panel with clear bright LED display
- Double skin construction for cool safe outer case temperature
- Over-temperature protection (recommended to protect valuable contents & for unattended operation)

Options (specify these at time of order)

- A range of sophisticated digital controllers, multi-segment programmers and data loggers is available. These can be fitted with RS232, RS485 or Ethernet communications (see pages 88-91)
- ISO-14644-1 Class 5 models are optionally available
- Top access port for independent thermocouple
- Cable access port
- Lockable door
- Door switch
- Fixed or castor mounted floor stands
- Through wall (flange fitted) as well as fully bespoke designs are available

Technical data

Model	Max temp (°C)	Temp stability (°C)	Temp uniformity (°C)	Heat-up time (mins)	Recovery time (mins)	Dimensions: Internal H x W x D (mm)	Dimensions: External H x W x D (mm)	Shelves fitted / accepted	Shelf loading each / total (kg)	Volume (litres)	Max power (W)
HTCR 4/28	400	±0.5	±5.0 @ 250°C	50	10	305 x 305 x 305	880 x 675 x 885 (Bench-top or optional stand)	2 / 2	10 / 20	28	1000
HTCR 4/95	400	±0.5	±5.0 @ 250°C	90	10	455 x 455 x 455	1010 x 810 x 1120 (Bench-top or optional stand)	3 / 5	15 / 30	94	3000
HTCR 4/220	400	±0.5	±5.0 @ 250°C	75	16	610 x 610 x 610	1160 x 1030 x 1280 (Bench-top or optional stand)	3 / 5	10 / 50	227	3000
HTCR 4/500	400	±0.5	±5.0 @ 250°C	-	-	800 x 800 x 800	1305 x 1115 x 1450 (Floor-standing or optional stand)	3 / 5	-	510	7500
HTCR 4/1000	400	±0.5	±5.0 @ 250°C	-	-	1000 x 1000 x 1000	1310 x 1530 x 1635 (Floor-standing or optional stand)	3 / 5	-	1000	12000
HTCR 5/28	500	±0.5	±5.0 @ 250°C	75	16	305 x 305 x 305	880 x 675 x 885 (Bench-top or optional stand)	2 / 2	10 / 20	28	2000
HTCR 5/95	500	±0.5	±5.0 @ 250°C	110	16	455 x 455 x 455	1010 x 810 x 1120 (Bench-top or optional stand)	3 / 5	15 / 30	94	3000
HTCR 5/220	500	±0.5	±5.0 @ 250°C	105	16	610 x 610 x 610	1160 x 1030 x 1280 (Bench-top or optional stand)	3 / 5	10 / 50	227	4500
HTCR 5/500	500	±0.5	±5.0 @ 250°C	-	-	800 x 800 x 800	1305 x 1155 x 1450 (Floor-standing or optional stand)	3 / 5	10 / 20	510	9000
HTCR 5/1000	500	±0.5	±5.0 @ 250°C	-	-	1000 x 1000 x 1000	1310 x 1530 x 1635 (Floor-standing or optional stand)	3 / 5	15 / 30	1000	15000
HTCR 6/28	600	±0.5	±5.0 @ 250°C	110	20	305 x 305 x 305	880 x 675 x 885 (Bench-top or optional stand)	2 / 2	10 / 50	28	2000
HTCR 6/95	600	±0.5	±5.0 @ 250°C	110	20	455 x 455 x 455	1010 x 810 x 1120 (Bench-top or optional stand)	3 / 5	10 / 20	94	4500
HTCR 6/220	600	±0.5	±5.0 @ 250°C	120	20	610 x 610 x 610	1160 x 1030 x 1280 (Bench-top or optional stand)	3 / 5	15 / 30	227	6000
HTCR 6/500	600	±0.5	±5.0 @ 250°C	-	-	800 x 800 x 800	1305 x 1155 x 1450 (Floor-standing or optional stand)	3 / 5	-	510	12000
HTCR 6/1000	600	±0.5	±5.0 @ 250°C	-	-	1000 x 1000 x 1000	1310 x 1530 x 1635 (Floor-standing or optional stand)	3 / 5	-	1000	15000

i Please note:

- Minimum operating temperature approximately ambient plus 60°C
- Uniformity is measured in an empty chamber with vents closed, after a stabilisation period
- Maximum power and heat up time based on a 240 V supply

- The uniform volume is smaller than the overall chamber volume

The 750 °C HRF air recirculation ovens comprise two bench-mounted models and two floor-standing models.

Equipped with powerful fans and horizontal air-guides these models are intended to provide rapid heating with high thermal transfer to the chamber contents and high uniformity within the chamber.

These designs frequently form the base from which custom designed chambers with non-standard sizes or control configurations are made. HRF ovens are often supplied with modifications to enable heat treatment within AMS 2750E Nadcap compliant production environments.



HRF 7/22

Airflow in HRF

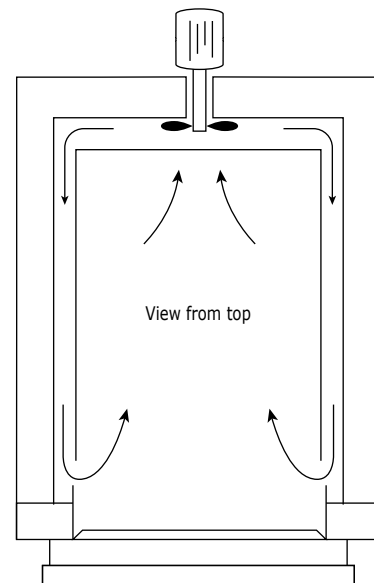

Standard features

- 750 °C maximum operating temperature
- 22, 45, 112 or 324 litre chamber volumes
- Wire elements located in both sides of the chamber
- Stainless steel liner
- Combination of low thermal mass and refractory board insulation
- Carbolite 301 controller, with single ramp to setpoint & process timer

Options (specify these at time of order)

- Over-temperature protection (recommended to protect valuable contents & for unattended operation)
- A range of sophisticated digital controllers, multi-segment programmers and data loggers is available. These can be fitted with RS232, RS485 or Ethernet communications (see pages 88-91)
- Additional sets of shelves & runners

Technical data

Model	Max temp (°C)	Heat-up time (mins)	Dimensions: Internal H x W x D (mm)	Dimensions: External H x W x D (mm)	Shelves fitted / accepted	Volume (litres)	Max power (W)	Thermocouple type	Weight (kg)
HRF 7/22C	750	63	220 x 200 x 495	590 x 450 x 870 (Bench-top)	0/3	22	3000	K	61
HRF 7/45B	750	-	295 x 265 x 560	840 x 600 x 1000 (Bench-top)	0/3	45	6000	K	110
HRF 7/112	750	-	400 x 400 x 700	1550 x 1000 x 1600 (Floor-standing)	0/2	112	18000	K	480
HRF 7/324	750	-	600 x 600 x 900	1800 x 1200 x 2280 (Floor-standing)	1/1	324	24000	K	1000

i Please note:
 - External dimensions with door closed and including chimney
 - Heat up rate is measured to 100 °C below max, using an empty chamber

- Maximum power and heat up time based on a 240 V supply
 - HRF 7/22 and HRF 7/45 have 3 integral shelf runners

The GP general purpose 300°C ovens are supplied in three sizes and two configurations: vertical (A) and horizontal (B) airflow.

This range also provides a foundation upon which a wide range of custom modifications can be added. Typical examples of which are the more sophisticated control systems and data recording that is required for applications such as AMS 2750E heat treatment under Nadcap, or modifications to handle heavier loads or assist in loading and unloading the oven, or simply larger chamber sizes than are offered in the standard range.



GP 450A & GP 220A

Standard features

- 300 °C maximum operating temperature
- Carbolite 301 controller with single ramp to setpoint facility
- Powerful vertical (A) or horizontal (B) airflow for optimum uniformity
- Built to withstand the rigours of a production environment
- Long lasting, polished 430 grade ferritic stainless steel internal case
- Robust external construction from steel section & zinc coated mild steel panels
- Mineral insulated metal sheathed heating elements
- Low thermal mass insulation
- Adjustable chamber ventilation

Options (specify these at time of order)

- Over-temperature protection (recommended to protect valuable contents & for unattended operation)
- A range of sophisticated digital controllers, multi-segment programmers and data loggers is available. These can be fitted with RS232, RS485 or Ethernet communications (see pages 88-91)
- Port for independent thermocouple
- Cable access ports
- Bespoke models are available for AMS2750E (Nadcap) compliant applications
- Additional shelves

Technical data

Model	Max temp (°C)	Temp stability (°C)	Temp uniformity (°C)	Heat-up time (mins)	Recovery time (mins)	Dimensions: Internal H x W x D (mm)	Dimensions: External H x W x D (mm)	Shelves fitted / accepted	Shelf loading each / total (kg)	Doors	Volume (litres)	Air changes / hr	Max power (W)
GP 220A	300	±0.5	±5.0	75	24	610 x 610 x 610	1240 x 862 x 850 (Bench-top)	3 / 5	15 / 45	Single door	220	160	3000
GP 330A	300	±0.5	±5.0	80	28	915 x 610 x 610	1545 x 862 x 850 (Floor-standing or optional stand)	4 / 8	15 / 60	Single door	330	110	4500
GP 450A	300	±0.5	±5.0	75	30	1220 x 610 x 610	1850 x 862 x 850 (Floor-standing)	5 / 11	15 / 75	Single door	450	80	6000
GP 220B	300	±0.5	±5.0	75	24	610 x 610 x 610	910 x 1190 x 850 (Bench-top)	3 / 15	15 / 45	Single door	220	160	3000
GP 330B	300	±0.5	±5.0	80	30	610 x 915 x 610	910 x 1495 x 850 (Bench-top)	3 / 5	15 / 45	Double Door	330	110	4500
GP 450B	300	±0.5	±5.0	75	35	610 x 1220 x 610	910 x 1800 x 850 (Bench-top)	3 / 5	20 / 60	Double Door	450	80	6000

i Please note:

- Minimum operating temperature approximately ambient plus 30 °C
- Uniformity is measured in an empty chamber with vents closed, after a stabilisation period
- Maximum power and heat up time based on a 240 V supply

- Shelf loadings are based on evenly distributed weight
- The uniform volume is smaller than the total chamber volume

The LGP large general purpose ovens offer the greatest choice of options in size and maximum temperature. The range spans from 500 to more than 13,000 litres, with a temperature span from 250°C to 700°C.

The LGP range is often customised in order to precisely meet the user's requirements.

Typical examples of which are the more sophisticated control systems and data recording that is required for applications such as AMS 2750E heat treatment under Nadcap, or modifications to handle heavier loads or assist in loading and unloading the oven, or simply larger chamber sizes than are offered in the standard range.

Standard features

- 250°C, 425°C, 625°C or 700°C maximum operating temperatures
- 500 to 13,820 litre chamber volumes
- PID digital set and display using the 2216 controller
- Large capacity, rugged well proven designs
- Robust construction, for heavy duty cycles
- Efficient air circulation and excellent temperature uniformity from heavy duty impellers
- Corrosion resistant ferritic grade 430 stainless steel interior
- Steel section & zinc coated, painted mild steel exterior
- Single & double door models
- Shelf runners on models up to 1000 litres (optional on models up to 5830 litres)
- Low thermal mass insulation for fast response & energy efficiency
- Fully adjustable chamber ventilation



LGP 2/3370



LGP 4/1000

Options (specify these at time of order)

- Over-temperature protection (recommended to protect valuable contents & for unattended operation)
- A range of sophisticated digital controllers, multi-segment programmers and data loggers is available. These can be fitted with RS232, RS485 or Ethernet communications (see pages 88-91)
- Bespoke models are available for AMS2750E (Nadcap) compliant applications
- Access ports for cables & pipes
- Exhaust proving switch
- Manual or motorised vertically opening doors
- Vertical airflow impellers
- Explosion relief panels
- Interior light (subject to temperature limitations)
- Standard or heavy duty shelves
- A wide range of sample loading & handling accessories can also be supplied

Shelf runners and shelves information

Models 500, 730 and 1000 litres: supplied with 4 pairs of shelf runners as standard. Shelves are available at extra cost.

For the following models the shelf runners and shelves are available at additional cost:

Models 1500, 2160 and 3370 litres: available with 7 pairs of shelf runners.

Model 1750 litres: available with 5 pairs of shelf runners.

Model 5830 litres: available with 9 pairs of shelf runners.

Larger capacity models are not supplied with any shelf runners.

Technical data

Model	Max temp (°C)	Temp stability (°C)	Temp uniformity (°C)	Heat-up time (mins)	Dimensions: Internal H x W x D (mm)	Dimensions: External H x W x D (mm)	Doors	Shelf loading each / total (kg)	Volume (litres)	Max power (W)
LGP 2/500	250	±0.5	±5.0 @250°C	60	800 x 800 x 800	1240 x 1725 x 1375	Single door	50 / 200	500	9000
LGP 2/730	250	±0.5	±5.0 @250°C	60	900 x 900 x 900	1265 x 1775 x 1450	Single door	50 / 200	730	9000
LGP 2/1000	250	±0.5	±5.0 @250°C	60	1000 x 1000 x 1000	1375 x 1900 x 1450	Single door	50 / 200	1000	12000
LGP 2/1500	250	±0.5	±5.0 @250°C	60	1500 x 1000 x 1000	1900 x 1900 x 1450	Single door	50 / 350	1500	15000
LGP 2/1750	250	±0.5	±5.0 @250°C	60	1200 x 1200 x 1200	1600 x 2100 x 1700	Single door	50 / 250	1750	18000
LGP 2/2160	250	±0.5	±5.0 @250°C	60	1500 x 1200 x 1200	1900 x 2100 x 1700	Single door	50 / 350	2160	18000
LGP 2/3370	250	±0.5	±5.0 @250°C	60	1500 x 1500 x 1500	1900 x 2400 x 2000	Single door	50 / 350	3370	24000
LGP 2/5830	250	±0.5	±5.0 @250°C	60	1800 x 1800 x 1800	2200 x 2700 x 2300	Double door	50 / 450	5830	35000
LGP 2/8000	250	±0.5	±5.0 @250°C	60	2000 x 2000 x 2000	2400 x 2800 x 2900	Double door	-	8000	42000
LGP 2/13820	250	±0.5	±5.0 @250°C	60	2400 x 2400 x 2400	2800 x 3200 x 3300	Double door	-	13820	60000
LGP 4/500	425	±0.5	±5.0 @250°C	60	800 x 800 x 800	1245 x 1725 x 1375	Single door	50 / 200	500	9000
LGP 4/730	425	±0.5	±5.0 @250°C	60	900 x 900 x 900	1265 x 1775 x 1375	Single door	50 / 200	730	12000
LGP 4/1000	425	±0.5	±5.0 @250°C	60	1000 x 1000 x 1000	1375 x 1900 x 1450	Single door	50 / 200	1000	18000
LGP 4/1500	425	±0.5	±5.0 @250°C	60	1500 x 1000 x 1000	1900 x 1900 x 1450	Single door	50 / 350	1500	21000
LGP 4/1750	425	±0.5	±5.0 @250°C	60	1200 x 1200 x 1200	1600 x 2100 x 1700	Single door	50 / 250	1750	24000
LGP 4/3370	425	±0.5	±5.0 @250°C	60	1500 x 1500 x 1500	1900 x 2100 x 1700	Single door	50 / 350	3370	33000
LGP 4/5830	425	±0.5	±5.0 @250°C	60	1800 x 1800 x 1800	1900 x 2400 x 2000	Double door	50 / 350	5830	48000
LGP 4/8000	425	±0.5	±5.0 @250°C	60	2000 x 2000 x 2000	2200 x 2700 x 2300	Double door	50 / 450	8000	54000
LGP 6/500	625	±0.5	±5.0 @250°C	75	800 x 800 x 800	1240 x 1725 x 1375	Single door	50 / 200	500	15000
LGP 6/730	625	±0.5	±5.0 @250°C	75	900 x 900 x 900	1265 x 1775 x 1375	Single door	50 / 200	730	18000
LGP 6/1000	625	±0.5	±5.0 @250°C	75	1000 x 1000 x 1000	1375 x 1900 x 1450	Single door	50 / 200	1000	24000
LGP 6/1500	625	±0.5	±5.0 @250°C	75	1500 x 1000 x 1000	1900 x 1900 x 1450	Single door	50 / 350	1500	30000
LGP 6/1750	625	±0.5	±5.0 @250°C	75	1200 x 1200 x 1200	1600 x 2100 x 1700	Single door	50 / 250	1750	36000
LGP 6/3370	625	±0.5	±5.0 @250°C	75	1500 x 1500 x 1500	1900 x 2100 x 1700	Double door	50 / 350	3370	48000
LGP 6/5830	625	±0.5	±5.0 @250°C	75	1800 x 1800 x 1800	1900 x 2400 x 2000	Double door	50 / 450	5830	72000
LGP 7/500	700	±0.5	±5.0 @250°C	-	800 x 800 x 800	1240 x 1725 x 1375	Single door	50 / 200	500	18000
LGP 7/730	700	±0.5	±5.0 @250°C	-	900 x 900 x 900	1265 x 1775 x 1375	Single door	50 / 200	730	24000
LGP 7/1000	700	±0.5	±5.0 @250°C	-	1000 x 1000 x 1000	1375 x 1900 x 1450	Single door	50 / 200	1000	30000
LGP 7/1500	700	±0.5	±5.0 @250°C	-	1500 x 1000 x 1000	1900 x 1900 x 1450	Single door	50 / 350	1500	36000
LGP 7/1750	700	±0.5	±5.0 @250°C	-	1200 x 1200 x 1200	1600 x 2100 x 1700	Single door	50 / 250	1750	48000

i Please note:

- Minimum operating temperature approximately ambient plus 35°C
- Uniformity is measured in an empty chamber with vents closed, after a stabilisation period
- Maximum power and heat up time based on a 240 V supply

- Shelf loadings are based on evenly distributed weight
- The uniform volume is smaller than the overall chamber volume

Products in this section include an extensive range of chamber and tube furnaces with maximum operating temperatures up to 1300 °C. The range of tube furnaces includes horizontal and vertical, single and 3-zone models as well as models specifically for use under vacuum and a tube furnace for carbon-14 and tritium analysis.

750 °C - 1300 °C

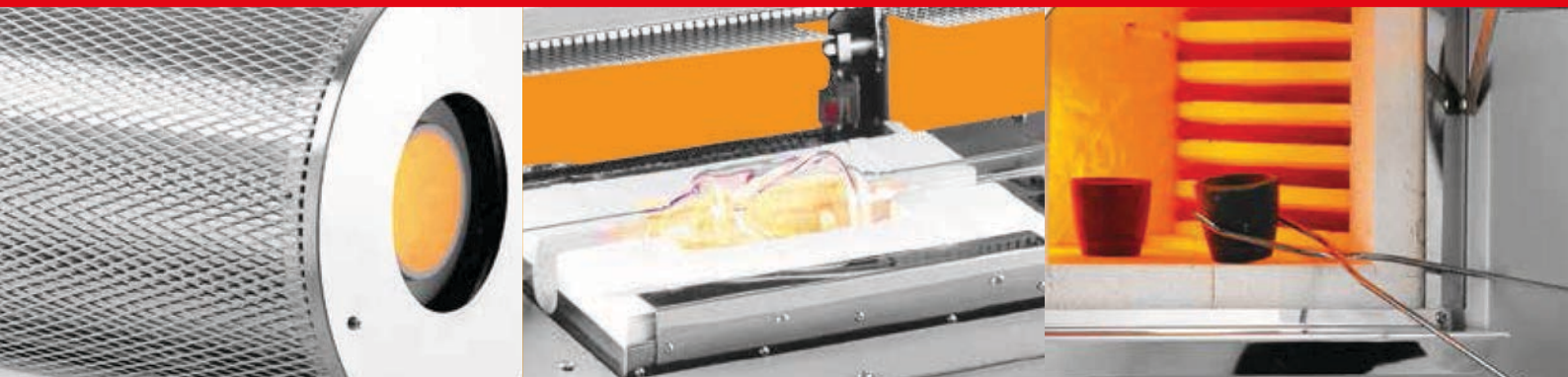

Temperature Range 750 °C – 1300 °C	Models	Page
Chamber Furnaces Selection Guide		28
Universal Chamber Furnaces	ELF, CWF, RWF, VCF	30
Ashing Furnaces Selection Guide		29
Ashing Chamber Furnaces	AAF, GSM, BWF, ABF	34
Tube Furnaces Selection Guide		38
Universal Tube Furnaces	MTF, CTF 12, EHA, EVA, EST, EVT, HST, VST 12, GHA, GVA, HTR	40
Three Zone Tube Furnaces	TZF, EHC, EVC, EZS, EVZ, HZS, TVS, GHC, GVC	49
Application Specific Furnaces	MTT, HVTT, PTC, CF	56
Industrial Batch Furnaces	GPC, LCF	60
Product Configurations		88

Carbolite's extensive chamber furnace range has a maximum operating temperature of 1800 °C and chamber capacities up to 725 litres. They are suitable for a variety of laboratory, pilot scale and industrial applications. Although there is flexibility in size and temperature, if the application requires the use of modified atmosphere (above 1100 °C) or vacuum then a furnace from Carbolite's tube furnace range should be selected.

The selection of a chamber furnace should take into account the following factors:

General considerations

- Chamber furnaces have the advantage of being able to heat larger items than tube furnaces
- The size of the chamber required and how it is loaded/unloaded will determine which style of furnace is best for the application
- For applications involving chemical vapours, gases or humidity please check with Carbolite or your local dealer which furnace meets the requirements

What temperature?

- Carbolite considers all products above 750 °C which are heated using radiant heat, (rather than convection), as furnaces
- The range of chamber furnaces is available up to a maximum operating temperature of 1800 °C
- Continuous operation of a furnace at its maximum temperature will reduce its life. Recommended maximum continuous operating temperature is 100 °C below the maximum operating temperature
- Furnaces are designed to operate at high temperatures. Operation below temperatures of approximately 600 °C will be less accurate and continuous use at low temperatures may reduce the element life of some furnaces, ie MoSi₂ heated furnaces
- Each furnace has a uniform working volume; this is a three-dimensional space which meets a specific tolerance and is smaller than the total chamber volume

Chamber design

- The simplest and least expensive furnaces have front opening side or bottom-hinged doors
- Higher specification front opening 'up and away' vertically lifting doors keep the hot face insulation away from the operator, increasing safety and comfort
- Where tall objects and crucibles need lifting in and out of the chamber, vertically loading furnaces with heating elements in the chamber sides are available
- Bottom loading furnaces allow the load to be lifted into the heated chamber, or lowered to cool them

Modified atmosphere

To work with inert gases or modified atmosphere, one of the following options must be selected at order placement:

- A gasket, elastomer seal or sand sealed retort in a front opening chamber furnace
- An inverted crucible on a modified hearth in a bottom loading furnace (BLF 1700 °C and 1800 °C models)

Temperature control

- All furnaces are supplied with accurate PID (proportional, integral and derivative) single ramp to setpoint controllers providing accurate control and minimal temperature overshoot. Higher temperature furnaces feature an 8-segment programmer as standard
- Multi-segment and/or multi-program controllers are available as an option on most models, please see pages 88-91
- Over-temperature protection is strongly recommended when a furnace is operating whilst unattended, or where the sample is valuable

Application specific and custom built furnaces

Carbolite designs and manufactures all the furnaces within its range. Many options are available, as well as fully customised furnaces for specific applications. For examples of custom built furnaces and ovens, please see pages 84-87.

One of the most common applications for laboratory furnaces is to heat combustible samples in order to analyse the ash residue. As there is no single solution for all requirements, Carbolite offers a range of furnaces with characteristics tailored to ashing and burn-off applications.

There are several important factors to consider, which will help to identify the correct furnace for successful ashing:

- Does the ashing process have to conform to a given test method, eg ISO/ASTM or other published standard?
- Does the ashing / burn-off process generate aggressive fumes which could damage the furnace or be hazardous?
- Will the furnace provide an adequate airflow to fully combust the sample?
- How large are the samples which must be ashed in order to provide a sufficiently large residue of ash for analysis?
- How intensive is the work cycle and how many samples must be processed?
- Would contamination of the ash with traces of alumina or silica (from conventional insulation materials) be detrimental?

Guide to ashing furnace selection

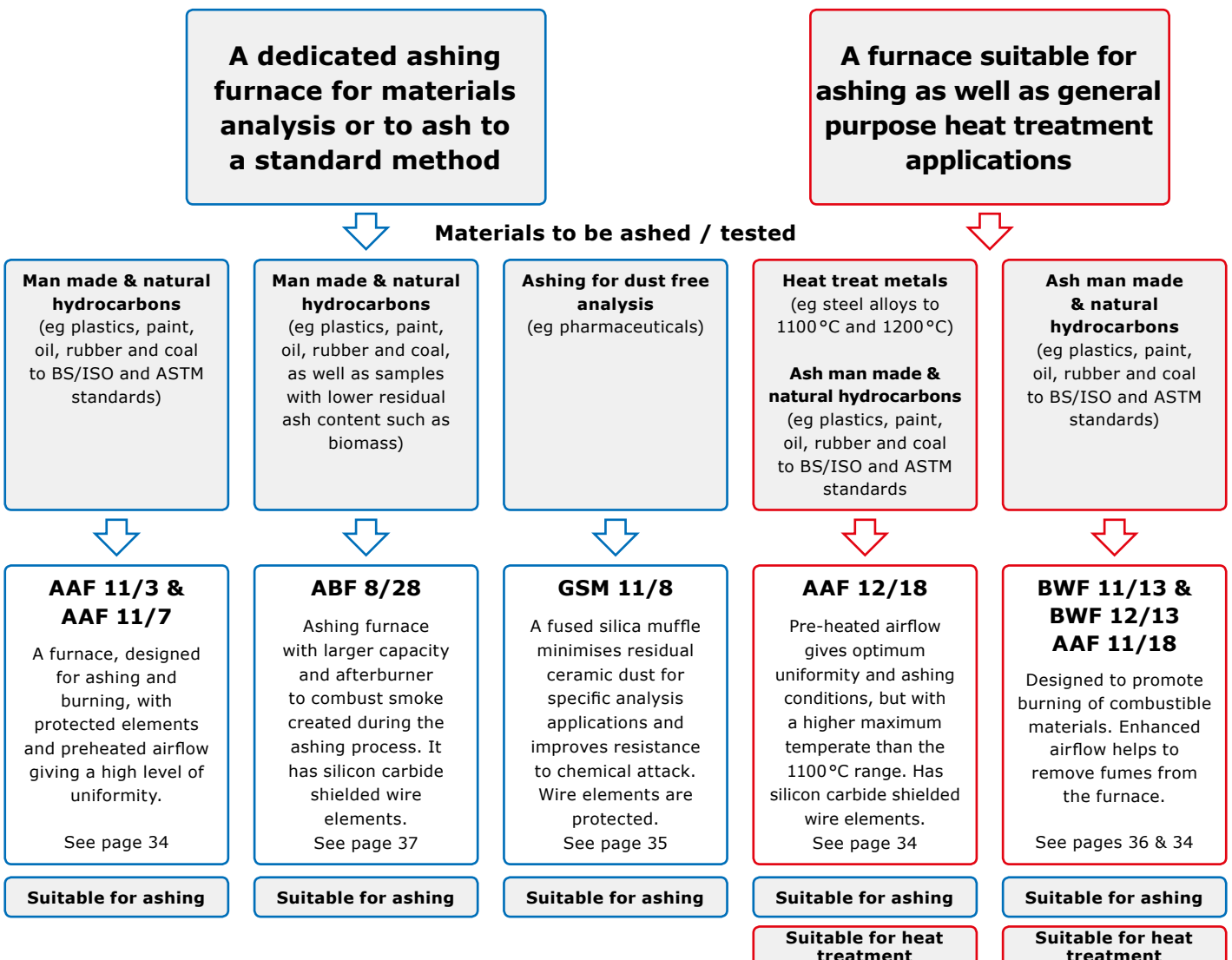

The ELF laboratory furnaces comprise 3 bench mounted models designed for light duty and general use up to 1100 °C.

They have a simple drop down door and a top mounted ceramic chimney. The combination of low thermal mass insulation and free radiating wire elements embedded in the chamber sides provide efficient heating.

Standard features

- 1100 °C maximum operating temperature
- 6, 14 or 23 litre chamber volumes
- Drop down door with air gap to minimise external temperature
- Carbolite 301 controller with single ramp to setpoint and process timer
- Delayed start / process timer function as standard
- Vacuum formed, low thermal mass insulation
- Hard ceramic hearth fitted as standard
- Ventilated via top mounted ceramic chimney



ELF 11/6

Options (specify these at time of order)

- Over-temperature protection (recommended to protect valuable contents & for unattended operation)

Heat-up and cool down rates for ELF 11/6

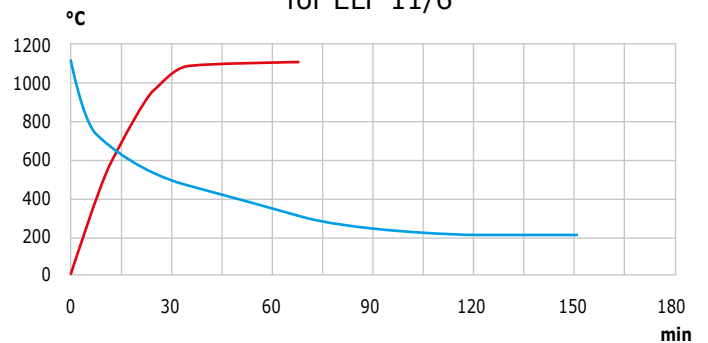

Technical data

Model	Max temp (°C)	Heat-up time (mins)	Max continuous operating temp (°C)	Dimensions: Internal H x W x D (mm)	Dimensions: External H x W x D (mm)	Temperature uniformity of ± 5°C within H x W x D (mm)	Volume (litres)	Max power (W)	Holding power (W)	Thermocouple type	Weight (kg)
ELF 11/6	1100	35	1000	165 x 180 x 210	580 x 410 x 420	125 x 140 x 140	6	2000	900	K	24
ELF 11/14	1100	40	1000	210 x 220 x 310	630 x 450 x 520	170 x 180 x 205	14	2600	1300	K	31
ELF 11/23	1100	29	1000	235 x 255 x 400	715 x 505 x 690	195 x 215 x 305	23	5000	1500	K	52

i Please note:
 - Heat up time is measured to 100°C below max, using an empty chamber
 - Holding power is measured at continuous operating temperature

- External dimensions with door closed and including chimney
 - The uniform volume is smaller than the total chamber volume

The CWF laboratory chamber furnaces range of general purpose furnaces is supplied in three sizes, each available with a maximum operating temperature of either 1100°C, 1200°C or 1300°C.

Standard features

- 1100°C, 1200°C or 1300°C maximum operating temperature
- 5, 13 or 23 litre chamber volumes
- Up & away door keeps heated surface away from the user
- Carbolite 301 controller with single ramp to setpoint and process timer
- Delayed start / process timer function as standard
- Hard wearing alumina element carriers, furnace entrance & hearth
- Energy efficient low thermal mass insulation
- Free radiating wire wound elements for optimum uniformity
- Easy access to elements & controls simplifies maintenance & servicing



CWF 11/13

Options (specify these at time of order)

- Over-temperature protection (recommended to protect valuable contents & for unattended operation)
- A range of sophisticated digital controllers, multi-segment programmers and data loggers is available. These can be fitted with RS232, RS485 or Ethernet communications (see pages 88-91)
- A variety of retorts & modifications are available for working with modified atmospheres

Technical data

Model	Max temp (°C)	Heat-up time (mins)	Max continuous operating temp (°C)	Dimensions: Internal H x W x D (mm)	Dimensions: External H x W x D (mm)	Dimensions: External with door open H x W x D (mm)	Temperature uniformity of ± 5°C within H x W x D (mm)	Volume (litres)	Max power (W)	Weight (kg)
CWF 11/5	1100	30	1000	135 x 140 x 250	585 x 375 x 485	800 x 375 x 485	85 x 90 x 110	5	2400	30
CWF 11/13	1100	80	1000	200 x 200 x 325	655 x 435 x 610	905 x 435 x 610	120 x 120 x 185	13	3100	47
CWF 11/23	1100	40	1000	235 x 245 x 400	705 x 505 x 675	990 x 505 x 675	155 x 165 x 285	23	7000	68
CWF 12/5	1200	35	1100	135 x 140 x 250	585 x 375 x 485	800 x 375 x 485	85 x 90 x 125	5	2400	30
CWF 12/13	1200	65	1100	200 x 200 x 325	655 x 435 x 610	905 x 435 x 610	120 x 120 x 200	13	3100	47
CWF 12/23	1200	45	1100	235 x 245 x 400	705 x 505 x 675	990 x 505 x 675	155 x 165 x 325	23	7000	68
CWF 13/5	1300	40	1200	135 x 140 x 250	585 x 375 x 485	800 x 375 x 485	85 x 90 x 150	5	2400	30
CWF 13/13	1300	80	1200	200 x 200 x 325	655 x 435 x 610	905 x 435 x 610	120 x 120 x 225	13	3100	47
CWF 13/23	1300	55	1200	235 x 245 x 400	705 x 505 x 675	990 x 505 x 675	155 x 165 x 340	23	7000	68

i Please note:

- Heat up time is measured to 100°C below max, using an empty chamber
- Holding power is measured at continuous operating temperature

- Maximum power and heat up time based on a 240 V supply
- The uniform volume is smaller than the total chamber volume

Universal Chamber Furnaces

32

RWF – Rapid Heating Chamber Furnaces

The RWF rapid wire chamber furnaces are available in three chamber sizes with maximum operating temperatures of 1100 °C or 1200 °C.

The free radiating wire elements in combination with low thermal mass insulation are designed to provide rapid thermal response within the chamber.

Standard features

- 1100 °C or 1200 °C maximum operating temperature
- 5, 13 or 23 litre chamber volumes
- Ambient to 1000 °C in as little as 10 minutes
- Rapid thermal response from free radiating coiled wire elements
- Low thermal mass insulation for fast response & energy efficiency
- Up & away door keeps heated surface away from the user
- Carbolite 301 controller, with single ramp to setpoint & process timer
- Hard wearing hearth



RWF 12/5

Options (specify these at time of order)

- Over-temperature protection (recommended to protect valuable contents & for unattended operation)
- A range of sophisticated digital controllers, multi-segment programmers and data loggers is available. These can be fitted with RS232, RS485 or Ethernet communications (see pages 88-91)

Heat-up rate for RWF 12/13

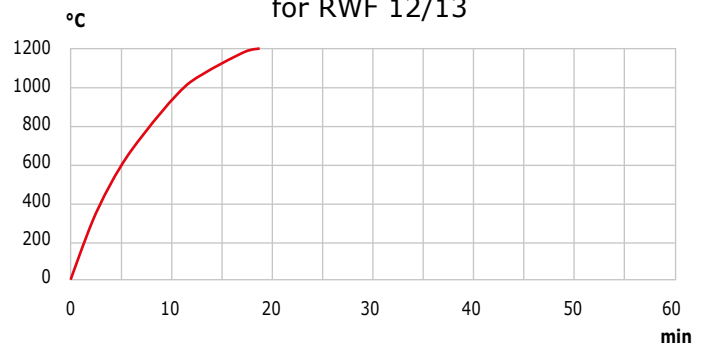

Technical data

Model	Max temp (°C)	Heat-up time (mins)	Max continuous operating temp (°C)	Dimensions: Internal H x W x D (mm)	Dimensions: External H x W x D (mm)	Dimensions: External with door open H x W x D (mm)	Volume (litres)	Max power (W)	Holding power (W)	Thermocouple type	Weight (kg)
RWF 11/5	1100	10	1000	130 x 160 x 250	585 x 375 x 325	800 x 375 x 325	5	2750	680	K	28
RWF 11/13	1100	11	1000	195 x 210 x 325	655 x 435 x 610	905 x 435 x 610	13	5000	1200	K	45
RWF 11/23	1100	13	1000	220 x 260 x 400	705 x 505 x 675	990 x 505 x 675	23	9100	1800	K	65
RWF 12/5	1200	12	1100	130 x 160 x 250	585 x 375 x 485	800 x 375 x 485	5	2750	820	R	28
RWF 12/13	1200	13	1100	195 x 210 x 325	655 x 435 x 610	905 x 435 x 610	13	5000	1450	R	45
RWF 12/23	1200	15	1100	220 x 260 x 400	705 x 505 x 675	990 x 505 x 675	23	9100	2100	R	65

i Please note:

- Heat up time is measured to 100 °C below max, using an empty chamber
- Holding power is measured at continuous operating temperature

- Maximum power and heat up time based on a 240 V supply
- The uniform volume is smaller than the total chamber volume

These top loading chamber furnaces are particularly suited for applications involving tall crucibles and heavy components.

Heating elements in all four walls minimise the risk of damage from spills and ensures good temperature uniformity. The smaller two furnaces may be bench-mounted, but best access is provided when these furnaces are located on the floor.

Standard features

- 1200 °C maximum operating temperature
- 5, 10, 23 or 100 litre chamber volume
- Free radiating wire elements in all 4 sides of chamber
- Vented top opening door
- Angled control panel, protected but clearly visible
- Carbolite 301 controller with single ramp to setpoint & process timer
- Thermocouple protected by ceramic sheath



VCF 12/5

Options (specify these at time of order)

- Over-temperature protection (recommended to protect valuable contents & for unattended operation)
- A range of sophisticated digital controllers, multi-segment programmers and data loggers is available. These can be fitted with RS232, RS485 or Ethernet communications (see pages 88-91)

Technical data

Model	Max temp (°C)	Heat-up time (mins)	Dimensions: Internal H x W x D (mm)	Dimensions: External H x W x D (mm)	Volume (litres)	Max power (W)	Holding power (W)	Thermocouple type	Weight (kg)
VCF 12/5	1200	102	260 x 155 x 130	660 x 530 x 405 (Floor-standing)	5	2500	900	R	50
VCF 12/10	1200	138	365 x 180 x 155	765 x 555 x 430 (Floor-standing)	10	3000	1200	R	60
VCF 12/23	1200	125	450 x 250 x 200	850 x 600 x 500 (Floor-standing)	23	6000	2500	R	130
VCF 12/100	1200	150	600 x 410 x 410	1100 x 930 x 950 (Floor-standing)	100	15000	6000	R	200

i Please note:
 - Heat up time is measured to 100°C below max, using an empty chamber
 - Holding power is measured at continuous operating temperature
 - The uniform volume is smaller than the total chamber volume

The range of AAF ashing furnaces is designed specifically to provide optimum ashing conditions to ensure complete combustion of the sample.

For those laboratories where ashing is interspersed with other heat treatment work the AAF 12/18 provides all of the advantages of the AAF design, but with a higher maximum operating temperature of 1200 °C.



AAF 11/3

Standard features

- Ideal for ashing foods, plastics, coal & other hydrocarbon materials
- Designed to comply with ISO 1171:2010 & ASTM D3174-04: 2010 (AAF 11/3 and AAF 11/7 only)
- Wire elements are protected from chemical & mechanical damage by a hard wearing alumina based liner (AAF 11/3 and AAF 11/7 only)
- AAF 11/18 and AAF 12/18 offer protection of the elements from carbon build-up or corrosive atmosphere, using silicon carbide tiles
- Air inlet & tall chimney give airflow of 4 to 5 changes per minute (AAF 11/3 and AAF 11/7 only)
- Low chamber height holds airflow close to samples for optimum combustion (AAF 11/3 and AAF 11/7 only)
- Powerful elements with graded winding compensate for heat loss due to high airflow (AAF 11/3 and AAF 11/7 only)
- Preheating of air before it enters the chamber gives excellent uniformity (AAF 11/3 and AAF 11/7 only)
- Large floor area allows for large number of samples
- AAF 11/3 and AAF 11/7 come complete with sample tray and loading handle
- AAF 11/18 and AAF 12/18 have two tier rack system doubling the sample capacity

Options (specify these at time of order)

- 2 phase electrical supply for AAF 11/7
- Over-temperature protection (recommended to protect valuable contents & for unattended operation)
- A range of sophisticated digital controllers, multi-segment programmers and data loggers is available. These can be fitted with RS232, RS485 or Ethernet communications (see pages 88-91)

Airflow in AAF 11/3 and AAF 11/7

- 1 A tall 50 mm diameter chimney (AAF 11/7), or 35 mm on AAF 11/3, pulls the air through the chamber
- 2 Pre-heated air enters the chamber after circulating around the outside of the chamber
- 3 Air inlet

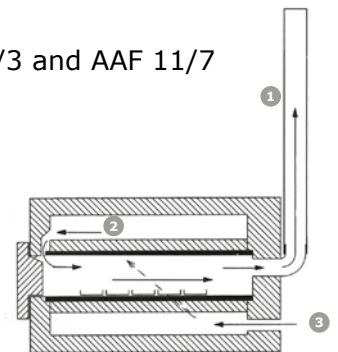

Technical data

Model	Max temp (°C)	Heat-up time (mins)	Max continuous operating temp (°C)	Dimensions: Internal H x W x D (mm)	Dimensions: External H x W x D (mm)	Dimensions: External with door open H x W x D (mm)	Dimensions: Height to top chimney (mm)	Volume (litres)	Max power (W)	Holding power (W)	Thermocouple type	Weight (kg)
AAF 11/3	1100	140	1000	90 x 150 x 250	585 x 375 x 485	800 x 375 x 485	780	3	2100	1270	K	22
AAF 11/7	1100	155	1000	90 x 170 x 455	650 x 430 x 740	905 x 430 x 740	1060	7	4000	2300	K	63
AAF 11/18	1100	70	1000	235 x 196 x 400	705 x 505 x 675	990 x 505 x 675	990	18	7080	3500	K	70
AAF 12/18	1200	70	1100	235 x 196 x 400	705 x 505 x 675	990 x 505 x 675	990	18	7080	3500	R	70

i Please note:
 - Holding power is measured at 500 °C
 - Heat up time is measured to 100 °C below max, using an empty chamber
 - Maximum power and heat up time based on a 240 V supply

Some analysis techniques may be affected by alumina or silica dust (Al_2O_3 and SiO_2) – the materials normally used to construct furnace chambers. To avoid this the GSM furnace chamber is constructed from a fused quartz material.

This design also offers superior containment of aggressive and corrosive vapours such as sulphuric, nitric and hydrochloric acids by keeping them away from the heating elements.

Additionally if an optional gas inlet is specified, the enclosed design minimises gas leakages from the chamber.

Standard features

- 1100°C maximum operating temperature
- Fused quartz furnace chamber, ideal for analyses where Al_2O_3 and SiO_2 could contaminate test results
- Chamber lining offers superior containment of corrosive & aggressive vapours such as H_2SO_4 , HNO_3 , HCl
- Moulded ceramic fibre door plug

Options (specify these at time of order)

- Gas inlet for modified atmospheres (the fused quartz liner provides improved containment)
- Sample trays & racks
- A range of sophisticated digital controllers, multi-segment programmers and data loggers is available. These can be fitted with RS232, RS485 or Ethernet communications (see pages 88-91)



- 1 AAF 11/3 tray
- 2 AAF 11/7 tray
- 3 AAF 11/18 & AAF 12/18 two tier rack system
- 4 Loading handle



GSM 11/8

Airflow in GSM

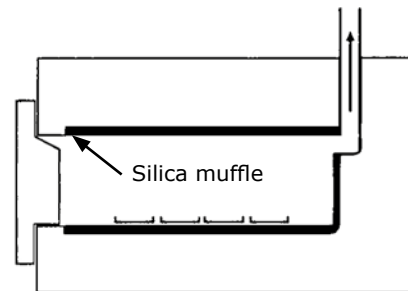

Technical data

Model	Max temp (°C)	Heat-up time (mins)	Max continuous operating temp (°C)	Dimensions: Internal H x W x D (mm)	Dimensions: External H x W x D (mm)	Dimensions: External with door open H x W x D (mm)	Dimensions: Height to top chimney (mm)	Volume (litres)	Max power (W)	Holding power (W)	Thermocouple type	Weight (kg)
GSM 11/8	1100	70	1000	120 x 175 x 345	655 x 435 x 750	895 x 435 x 750	1060	8	3050	1700	K	57

i Please note:

- Heat up time is measured to 100°C below max, using an empty chamber
- Holding power is measured at the continuous operating temperature

- Maximum power and heat up time based on a 240 V supply
- The maximum depth to accommodate the door opening arc is 810 mm

Ashing Chamber Furnaces

36

BWF – Burn-off Furnaces

The BWF burn-off furnace is designed to promote burning of combustible materials.

The airflow in the BWF is enhanced by the addition of a tall chimney and air inlet holes in the door, which rapidly remove the fumes from the furnace.

Standard features

- 1100 °C or 1200 °C maximum operating temperature
- Good uniformity & compensation for heat loss from graded wire wound elements in side mounted, hard wearing alumina carriers
- Hard wearing alumina element carrier, furnace entrance and hearth
- Enhanced airflow from high chimney & door vents for full combustion
- Carbolite 301 PID controller with single ramp to setpoint and process timer



BWF 12/13

Options (specify these at time of order)

- Optional racks & hearth trays
- A range of sophisticated digital controllers, multi-segment programmers and data loggers is available. These can be fitted with RS232, RS485 or Ethernet communications (see pages 88-91)

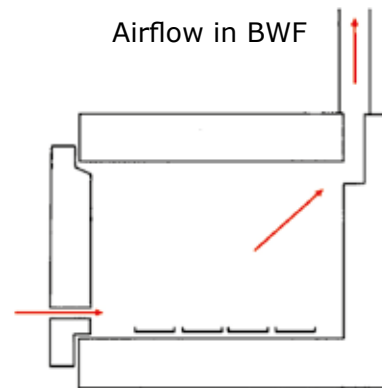

Technical data

Model	Max temp (°C)	Heat-up time (mins)	Max continuous operating temp (°C)	Dimensions: Internal H x W x D (mm)	Dimensions: External H x W x D (mm)	Dimensions: External with door open H x W x D (mm)	Dimensions: Height to top chimney (mm)	Volume (litres)	Max power (W)	Holding power (W)	Thermocouple type	Weight (kg)
BWF 11/13	1100	115	1000	200 x 200 x 325	655 x 435 x 610	905 x 435 x 610	800	13	3100	1200	K	47
BWF 12/13	1200	130	1100	200 x 200 x 325	655 x 435 x 610	905 x 435 x 610	800	13	3100	1500	R	47

- i** Please note:
- Heat up time is measured to 100 °C below max, using an empty chamber
 - Holding power is measured at the continuous operating temperature
 - Maximum power and heat up time based on a 240 V supply

The ABF afterburner ashing furnace is particularly suitable for ashing larger samples or materials such as biomass, which are likely to generate substantial amounts of smoke.

The furnace comprises a large main combustion chamber equipped as standard with a two tier set of sample baskets. The exhaust from the main chamber passes through a high temperature afterburner designed to further process fumes and smoke.

Standard features

- 800 °C maximum operating temperature – ashing chamber
- 28 litre chamber volume
- Afterburner rated for up to 40 g carbon per ashing load
- Two tier baskets with loading tray and handle
- 3216P1 programmable controller
- Independent control of afterburner temperature up to 950 °C
- Silicon carbide shielded wire wound elements
- Supplied with 3-phase supply as standard



ABF 8/28

Options (specify these at time of order)

- Over-temperature protection (recommended to protect valuable contents & for unattended operation)
- A range of sophisticated digital controllers, multi-segment programmers and data loggers is available. These can be fitted with RS232, RS485 or Ethernet communications (see pages 88-91)
- Optional floor stand

Technical data

Model	Max temp (°C)	Max continuous operating temp (°C)	Dimensions: Internal H x W x D (mm)	Dimensions: External H x W x D (mm)	Dimensions: Height to top chimney (mm)	Volume (litres)	Max power (W)	Holding power (W)	Thermocouple type	Weight (kg)
ABF 8/28	800	700	210 x 290 x 445	980 x 600 x 750 (Bench-top or optional stand)	1150	28	8000	3828	K	120

i Please note:
 - Holding power is measured at 500 °C
 - Heat up time is measured to 100 °C below max, using an empty chamber

Tube furnaces are frequently the most economical way to heat a small sample. Rapid temperature changes are possible by simply adding a push-rod to move the sample along the length of the tube (although care must be taken not to cause thermal shock to the tube or sample boat). Additionally, the use of a tube furnace makes controlling the temperature uniformity and atmosphere around the specimen easier.

The selection of a tube furnace should take into account the following factors:

What temperature?

- It is recommended to allow at least 100 °C extra heating range above the desired working temperature
- Standard models are available with maximum operating temperatures from 1000 °C to 1800 °C
- Different heating technologies are utilised to achieve each given temperature range

Size & work tubes?

- Some furnaces, most often those with wire wound elements, are supplied with an integral work tube, usually because the resistance wire element is wound directly onto the work tube
- For some tube furnaces an accessory work tube is essential
- An accessory work tube may be preferred either because of its material properties or to protect (where there is one) the wire wound work tube
- See the 'work tube' section (pages 92-94) for advice on selecting the correct work tube

Single or 3-zone?

- Tube furnaces provide a high level of uniformity
- For improved uniformity accessory insulation plugs or radiation shields should be purchased, especially for tube diameters >25 mm id
- The length of the central uniform zone can be further increased by adding heated zones at the ends in the form of a 3-zone furnace design

Modified atmosphere or vacuum?

- Tube furnaces are ideal when the sample must be heated in an inert atmosphere or a vacuum
- A combination of end seals protected by thermal radiation shields should be considered. A longer work tube is required to accommodate these

Horizontal or vertical?

- Most Carbolite tube furnaces are available in horizontal and vertical configurations
- When used vertically, end seals are strongly recommended to minimise the effects of convection currents through the work tube
- In vertical configurations the furnace body is separate from the control module and attached by a 2 metre conduit

Split tube models

- Both vertical and horizontally configured furnaces are available with the furnace body split and hinged along its length
- This enables easy access where work tubes are to be changed between jobs or where the furnace is to be wrapped around the sample for example in tensile test rigs

Application specific & bespoke designs

Rotary reactor, elevator tube and high vacuum tube furnaces are just some of the standard variations of tube furnaces available from Carbolite. Many other bespoke modifications can be provided offering alternative temperature ranges, dimensions, physical configurations, sample handling and functionality such as rotating tubes. Simply contact Carbolite or your local distributor for a quotation.

Mounting Configurations

Non-split tube furnaces

The standard configuration for the MTF, CTF, STF, GHA, GHC, EHA, EHC and TZF horizontal tube furnaces is for the furnace body to be mounted directly onto a control module.

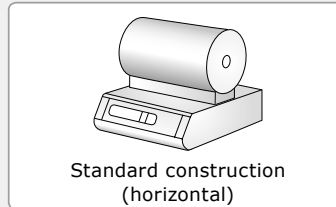

Other options are available at time of order. The furnace body can be mounted on a 'blanked base' linked via a 2 or 6 metre power conduit to a separate control module.

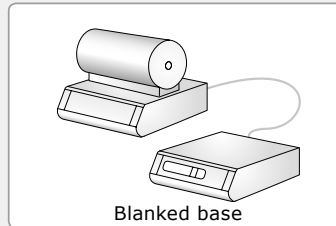

The furnace body can be supplied mounted on a separate 'L' stand which allows it to be freely positioned separately from the control module in either a horizontal or vertical position. Note that different work tube mounting accessories may be required to change from horizontal to vertical operation, or vice versa.

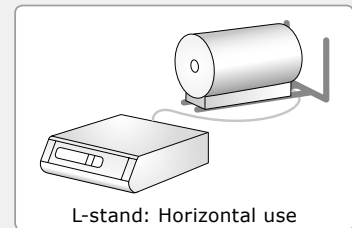
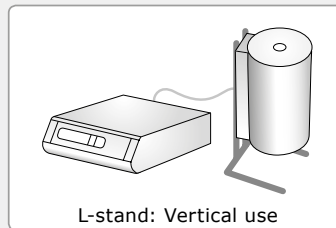

The furnace body may be supplied separately from the base and either completely without a stand or with a wall mounting bracket.

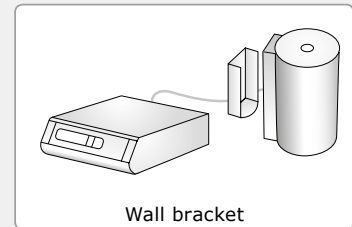
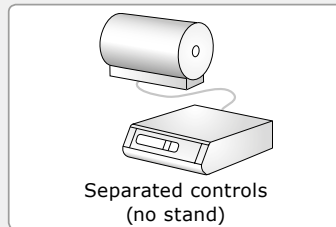

GVA and GVC tube furnaces are available with a complete 'G' pattern stand or optionally with just support rail portion of the stand (without the foot) with or without a wall mounting bracket.

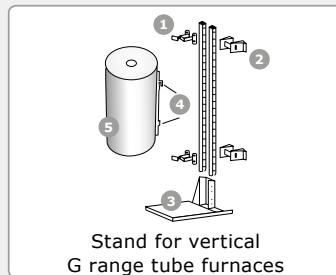

- 1 Horizontal tube support
- 2 Wall bracket
- 3 Foot
- 4 Support system
- 5 Body

Split tube furnaces

Split tube furnaces from the HST and HZS ranges are optionally available for dual vertical and horizontal use mounted upon an 'L' stand. VST and TVS vertical split tube furnaces are similarly available without stands and in 'far-hinge' designs as an alternative to the standard 'near-hinge' configuration. The 'far-hinge' configuration opens wide to give easier access when using large work tubes or test pieces.

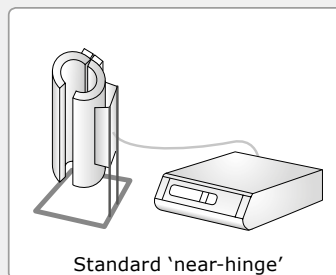

The MTF wire wound tube furnaces use a wire element that is wound directly onto a fixed integral ceramic work tube.

This simple and economical design provides a furnace which can be used without the need to purchase an accessory work tube. However, should vacuum or a modified atmosphere be required, it is necessary to use a separate slide-in work tube in order to provide the required length needed to fit end seals. Similarly, in some circumstances a work tube that has different physical or chemical properties to the fixed work tube may be required. The use of an additional slide-in work tube protects the integral work tube and heating element



MTF 12/25/250

Standard features

- 1000 °C or 1200 °C maximum operating temperature
- 15 mm, 25 mm or 38 mm inner diameters
- 130 mm, 250 mm, 400 mm or 850 mm heated length
- Integral wire wound work tube
- Carbolite 301 controller with single ramp to setpoint and process timer
- Delayed start / process timer function as standard
- Horizontal configuration mounted on control module

Options (specify these at time of order)

- Over-temperature protection (recommended to protect valuable contents & for unattended operation)
- A range of additional work tubes is available in a variety of materials
- Insulation plugs & radiation shields to prevent heat loss & improve uniformity
- Modified atmosphere and vacuum end seal assemblies (see page 95)
- Alternative mounting configurations are available (see page 39)
- A range of sophisticated digital controllers, multi-segment programmers and data loggers is available. These can be fitted with RS232, RS485 or Ethernet communications (see pages 88-91)

Technical data

Model	Max temp (°C)	Heat-up time (mins)	Max continuous operating temp (°C)	Dimensions: Fixed tube inner diameter (mm)	Dimensions: Heated length (mm)	Dimensions: External H x W x D (mm)	Dimensions: Furnace body length (mm)	Uniform length ±5°C (mm)	Max power (W)	Holding power (W)	Thermocouple type	Weight (kg)
MTF 10/15/130	1000	5	900	15	130	360 x 200 x 240	150	30	400	100	K	3
MTF 10/25/130	1000	10	900	25	130	360 x 200 x 240	150	45	400	100	K	3
MTF 12/25/250	1200	15	1100	25	250	375 x 370 x 375	300	60	700	200	N	10
MTF 12/38/250	1200	25	1100	38	250	375 x 450 x 375	300	90	1000	300	N	15
MTF 12/25/400	1200	30	1100	25	400	430 x 370 x 375	450	100	1000	200	N	15
MTF 12/38/400	1200	25	1100	38	400	430 x 450 x 375	450	130	1500	300	N	17
MTF 12/38/850	1200	-	1100	38	850	430 x 900 x 375	900	500	2800	-	N	24

i Please note:

- Heat up time is measured to 100°C below max, using an empty tube & insulation plugs
- Holding power is measured at the continuous operating temperature

- Maximum power and heat up time based on a 240 V supply
- Uniform length ±5°C (mm): Uniform temperature lengths are measured with insulation plugs fitted

The CTF wire wound tube furnaces use a wire element that is wound directly onto a fixed diameter integral ceramic work tube. The CTF range offers tube diameters of 65, 75 and 100 mm (inner diameters).

This simple and economical design provides a furnace that can be used without the need to purchase an additional work tube. However, should vacuum or a modified atmosphere be required, it is necessary to use a separate additional slide-in work tube in order to provide the required length needed to fit end seals. Similarly, in some circumstances a work tube that has different physical or chemical properties to the fixed work tube may be required. The use of an additional slide-in work tube protects the integral work tube and heating element.



CTF 12/65/550

Standard features

- 1200 °C maximum operating temperature
- 65 mm, 75 mm or 100 mm work tube inner diameters
- 550 mm, 700 mm or 900 mm heated length
- Integral wire wound work tube
- Carbolite 301 PID controller single ramp to setpoint and process timer
- Delayed start / process timer function as standard
- Horizontal configuration mounted on control module

Options (specify these at time of order)

- Alternative mounting options are available (see page 39)
- Optionally configured for 2 phase electrical supply
- A range of additional work tubes is available in a variety of materials
- Insulation plugs & radiation shields to prevent heat loss & improve uniformity
- Modified atmosphere and vacuum end seal assemblies (see page 95)
- Over-temperature protection (recommended to protect valuable contents & for unattended operation)
- A range of sophisticated digital controllers, multi-segment programmers and data loggers is available. These can be fitted with RS232, RS485 or Ethernet communications (see pages 88-91)

Technical data

Model	Max temp (°C)	Heat-up time (mins)	Max continuous operating temp (°C)	Dimensions: Fixed tube inner diameter (mm)	Dimensions: Heated length (mm)	Dimensions: External H x W x D (mm)	Dimensions: Furnace body length (mm)	Uniform length ±5°C (mm)	Max power (W)	Thermocouple type	Weight (kg)
CTF 12/65/550	1200	45	1100	65	550	525 x 625 x 360	600	230	2000	N	25
CTF 12/75/700	1200	45	1100	75	700	525 x 775 x 360	750	265	3000	N	28
CTF 12/100/900	1200	90	1100	100	900	525 x 975 x 360	950	640	4500	N	35

- i** Please note:
- Heat up time is measured to 100°C below max, using an empty tube & insulation plugs
 - Uniform length ±5 °C (mm): Uniform temperature lengths are measured with insulation plugs fitted
 - Maximum power and heat up time based on a 240 V supply

**EHA, EVA, EST and EVT –
Compact Modular Tube Furnaces**

These universal tube furnaces use free radiating wire elements embedded within the insulation of the furnace body. The benefit of this design is its flexibility; with the use of tube adapters the same furnace can be used with a variety of tube diameters. The furnaces are available with horizontal or vertical, split and non-split configuration.

The models EST and EVT comprise a furnace body which is hinged and split into two halves along its length. This makes exchange of work tubes easier and also enables the furnace to be used with reactors or work tubes where end flanges would make insertion into a non-split furnace difficult.

This range of tube furnaces does not include an integral work tube and one must be selected as an additional item. The work tube length is dependent on the application eg for use with modified atmosphere or vacuum; this information can be found on pages 92-93. The use of a separate work tube has the advantage of protecting the heating elements from damage or contamination.



EHA 12/150

Standard features

- 1200 °C maximum operating temperature
- 150, 300, 450 or 600 mm heated lengths
- Accepts work tubes with outer diameters up to 60 mm
- Wire elements in high quality vacuum formed insulation ensure fast heat up, excellent temperature uniformity and short cool down times
- Models EST, EVT: Furnace splits into two halves and accommodates tubes or samples fixed into a test rig
- Models EHA, EST: Horizontal configuration
- Models EVA, EVT: Vertical configuration (can also be used horizontally)
- Models EVA, EVT: Control module with 2 metre conduit to furnace
- Carbolite 301 digital PID controller with single ramp to setpoint, digital display and process timer
- Outer mesh guard ensures operator safety

Options (specify these at time of order)

- EVA models: Angle adjustment option allows horizontal and multi-angle configuration (see page 51)
- A range of sophisticated digital controllers, multi-segment programmers and data loggers is available. These can be fitted with RS232, RS485 or Ethernet communications (see pages 88-91)
- Over-temperature protection (recommended to protect valuable contents & for unattended operation)
- Wide choice of tube diameters and materials is available: eg quartz, ceramic, metal. See pages 92-93 for tube materials and dimensions
- Insulation plugs and radiation shields to prevent heat loss and improve uniformity
- Modified atmosphere and vacuum end seal assemblies (see page 95)



EST 12/300

Technical data

Model	Configuration		Max temp (°C)	Heat up time (mins)	Dimensions: Max outer ø accessory tube (mm)	Heated length (mm)	Tube length for use in air (mm)	Tube length for use with modified atmosphere (mm)	Dimensions: External H x W x D (mm)	Uniform length ±5°C (mm)	Max power (W)	Thermo-couple Type	Weight (kg)
EHA 12/150	Non-Split	horizontal	1200	85	60	150	300	600	560 x 370 x 390	80	750	N	15
EHA 12/300	Non-Split	horizontal	1200	55	60	300	450	750	560 x 465 x 390	185	1480	N	17
EHA 12/450	Non-Split	horizontal	1200	55	60	450	600	900	560 x 615 x 390	300	2000	N	19
EHA 12/600	Non-Split	horizontal	1200	55	60	600	750	1050	560 x 765 x 390	460	2520	N	23
EVA 12/150	Non-Split	vertical	1200	-	60	150	300	600	710 x 545 x 545	75	750	N	20
EVA 12/300	Non-Split	vertical	1200	58	60	300	450	750	1040 x 545 x 545	180	1480	N	27
EVA 12/450	Non-Split	vertical	1200	58	60	450	600	900	1040 x 545 x 545	250	2000	N	29
EVA 12/600	Non-Split	vertical	1200	58	60	600	750	1050	1160 x 545 x 545	370	2520	N	33
EST 12/150	Split	horizontal	1200	85	60	150	300	600	560 x 370 x 390	80	750	N	16
EST 12/300	Split	horizontal	1200	55	60	300	450	750	560 x 465 x 390	185	1480	N	18
EST 12/450	Split	horizontal	1200	55	60	450	600	900	560 x 615 x 390	300	2000	N	20
EST 12/600	Split	horizontal	1200	55	60	600	750	1050	560 x 765 x 390	460	2520	N	24
EVT 12/150	Split	vertical	1200	-	60	150	600	600	710 x 545 x 545	75	750	N	21
EVT 12/300	Split	vertical	1200	58	60	300	750	750	1040 x 545 x 545	180	1480	N	28
EVT 12/450	Split	vertical	1200	58	60	450	900	900	1040 x 545 x 545	250	2000	N	30
EVT 12/600	Split	vertical	1200	58	60	600	1050	1050	1160 x 545 x 545	370	2520	N	34

i Please note:

- Heat up rate is measured to 100°C below maximum, using an empty work tube and insulation plugs
- Holding power is measured at continuous operating temperature

- Maximum continuous operating temperature is 100°C below maximum temperature
- Models EVA and EVT dimensions excluding control box (225 x 370 x 390 mm)

HST – Horizontal Split Tube Furnaces

The HST tube furnaces use free radiating wire elements embedded within the insulation of the furnace body. The benefit of this design is its flexibility; with the use of tube adapters the same furnace can be used with a variety of tube diameters.

These furnaces comprise a furnace body which is hinged and split into two halves along its length. This makes exchange of work tubes easier and also enables the furnace to be used with reactors or work tubes where end flanges would make insertion into a non-split furnace difficult. This range of tube furnaces does not include an integral work tube and one must be selected as an additional item. The work tube length is dependent on the application eg for use with modified atmosphere or vacuum. This information can be found on pages 92-93.

The use of a separate work tube has the advantage of protecting the heating elements from damage or contamination.



HST 12/600

Standard features

- 1200°C maximum operating temperature
- Accepts work tubes with outer diameters up to 110 mm
- Heated lengths of 200, 300, 400, 600, 900 mm
- Horizontal furnace with a separate control module on a 2 metre conduit
- Furnace splits into two halves to accommodate work tubes or samples fixed into a test rig
- Wire elements in high quality vacuum formed insulation ensure fast heat up, excellent temperature uniformity and short cool down times
- Carbolite 301 digital PID controller with single ramp to setpoint, digital display and process timer

Options (specify these at time of order)

- Insulation plugs, gas tight end seals and vacuum connections available
- Wide choice of tube diameters and materials is available: eg quartz, ceramic, metal. See pages 92-93 for tube materials and dimensions
- Over-temperature control; recommended for unattended operation and to protect a valuable load
- Available with 'L' stand for vertical and horizontal use
- Control module on longer 6 metre conduit
- A range of sophisticated digital controllers, multi-segment programmers and data loggers is available. These can be fitted with RS232, RS485 or Ethernet communications (see pages 88-91)

Technical data

Model	Max temp (°C)	Heat-up time (mins)	Dimensions: Max outer diameter accessory tube (mm)	Dimensions: Heated length (mm)	Dimensions: Furnace body length (mm)	Recommended tube length for use in air (mm)	Recommended tube length for use with modified atmosphere (mm)	Dimensions: External Furnace (inc stand) H x W x D (mm)	Dimensions: Control module H x W x D (mm)	Uniform length ±5°C (mm)	Max power (W)	Thermo-couple type	Weight (kg)
HST 12/200	1200	45	110	200	350	350	650	350 x 350 x 410	222 x 370 x 376	100	1000	N	26
HST 12/300	1200	45	110	300	450	450	750	350 x 450 x 410	222 x 370 x 376	150	1500	N	28
HST 12/400	1200	45	110	400	550	550	850	350 x 550 x 410	222 x 370 x 376	200	2000	N	32
HST 12/600	1200	45	110	600	750	750	1050	350 x 750 x 410	222 x 370 x 376	300	3000	N	38
HST 12/900	1200	45	110	900	1050	1050	1350	350 x 1050 x 410	222 x 370 x 376	450	4500	N	60

i Please note:
 - Heat up rate is measured to 100°C below max, using an empty tube & insulation plugs
 - Uniform length measured with insulation plugs fitted
 - Maximum continuous operating temperature is 100°C below maximum temperature

The VST tube furnaces use free radiating wire elements embedded within the insulation of the furnace body. The benefit of this design is its flexibility; with the use of tube adapters the same furnace can be used with a variety of tube diameters.

These furnaces comprise a furnace body which is hinged and split into two halves along its length. This makes exchange of work tubes easier and also enables the furnace to be used with reactors or work tubes where end flanges would make insertion into a non-split furnace difficult. This design is particularly suitable for incorporation into extension test and creep test apparatus. This range of tube furnaces does not include an integral work tube and one must be selected as an additional item. The work tube length is dependent on the application eg for use with modified atmosphere or vacuum. This information can be found on pages 92-93. The use of a separate work tube has the advantage of protecting the heating elements from damage or contamination. The 'near-hinge' format is standard, an alternative option that can be specified at the time of purchase is the 'far-hinge' format, where the pivot of hinges is further from the centre line of the furnace to enable a wider opening action.



VST 12/600

Standard features

- 1200°C maximum operating temperature
- Accepts work tubes with outer diameters up to 110 mm
- Heated lengths of 200, 300, 400, 600, 900 mm
- Furnace splits into two halves and accommodates tubes or samples fixed into a test rig
- Wire elements in high quality vacuum formed insulation ensure fast heat up, excellent temperature uniformity and short cool down times
- Supplied in 'near-hinge' configuration complete with stand
- Vertical furnace with a separate control module on a 2 metre conduit (for vertical use only)
- Carbolite 301 digital PID controller with single ramp to setpoint, digital display and process timer

Options (specify these at time of order)

- Insulation plugs, gas tight end seals and vacuum connections available
- 'Far-hinge' configuration providing wider opening of furnace body
- Wide choice of tube diameters and materials is available: eg quartz, ceramic, metal. See pages 92-93 for tube materials and dimensions
- Over-temperature control; recommended for unattended operation and to protect a valuable load
- Control module on longer 6 metre conduit
- A range of sophisticated digital controllers, multi-segment programmers and data loggers is available. These can be fitted with RS232, RS485 or Ethernet communications (see pages 88-91)

Technical data

Model	Max temp (°C)	Heat-up time (mins)	Dimensions: Max outer diameter accessory tube (mm)	Dimensions: Heated length (mm)	Dimensions: Furnace body length (mm)	Recommended tube length for use in air (mm)	Recommended tube length for use with modified atmosphere (mm)	Dimensions: External Furnace (inc stand) H x W x D (mm)	Dimensions: Control module H x W x D (mm)	Max power (W)	Holding power (W)	Thermo-couple type	Weight (kg)
VST 12/200	1200	45	110	200	350	550	650	640 x 500 x 495	222 x 370 x 376	1000	800	N	24
VST 12/300	1200	45	110	300	450	650	750	740 x 500 x 495	222 x 370 x 376	1500	850	N	25
VST 12/400	1200	45	110	400	550	750	850	840 x 500 x 495	222 x 370 x 376	2000	900	N	26
VST 12/600	1200	45	110	600	750	950	1050	1040 x 500 x 495	222 x 370 x 376	3000	1100	N	32
VST 12/900	1200	45	110	900	1050	1250	1350	1340 x 500 x 675	222 x 370 x 376	4500	1450	N	44

i Please note:

- Heat up rate is measured to 100°C below max, using an empty tube & insulation plugs
- Maximum continuous operating temperature is 100°C below maximum

GHA – Modular Horizontal Tube Furnaces

The GHA tube furnaces use free radiating wire elements embedded within the insulation of the furnace body. The benefit of this design is its flexibility; with the use of tube adapters the same furnace can be used with a variety of tube diameters.

This range of tube furnaces does not include an integral work tube and one must be selected as an additional item. The work tube length is dependent on the application eg for use with modified atmosphere or vacuum. This information can be found on pages 92-93. The use of a separate work tube has the advantage of protecting the heating elements from damage or contamination.



GHA 12/300

Standard features

- 1200 °C maximum operating temperature
- Accepts work tubes with outer diameters up to 170 mm
- Heated lengths of 300, 450, 600, 750, 900, 1050 or 1200 mm
- Long life, rapid heating, resistance wire elements mounted in rigid, vacuum formed insulation modules
- Carbolite 301 digital PID controller with single ramp to setpoint, digital display and process timer
- Horizontal configuration
- Furnace mounted directly on top of controller base unit

Options (specify these at time of order)

- Wide choice of tube diameters and materials is available: eg quartz, ceramic, metal. See pages 92-93 for tube materials and dimensions
- Insulation plugs & radiation shields to prevent heat loss & improve uniformity
- Modified atmosphere and vacuum assemblies are available (see page 95)
- Over-temperature protection (recommended to protect valuable contents & for unattended operation)
- A range of sophisticated digital controllers, multi-segment programmers and data loggers is available. These can be fitted with RS232, RS485 or Ethernet communications (see pages 88-91)

Technical data

Model	Max temp (°C)	Heat-up time (mins)	Max continuous operating temp (°C)	Dimensions: Max outer diameter accessory tube (mm)	Dimensions: Heated length (mm)	Tube length for use in air (mm)	Tube length for use with modified atmosphere (mm)	Dimensions: External H x W x D (mm)	Dimensions: Furnace body length (mm)	Uniform length ±5°C (mm)	Max power (W)	Thermo-couple type	Weight (kg)
GHA 12/300	1200	90	1100	170	300	500	900	670 x 526 x 468	480	201	2300	N	35
GHA 12/450	1200	97	1100	170	450	650	1050	670 x 676 x 468	630	262	3100	N	37
GHA 12/600	1200	92	1100	170	600	800	1200	670 x 826 x 468	780	414	3900	N	40
GHA 12/750	1200	97	1100	170	750	950	1350	670 x 976 x 468	930	448	4600	N	51
GHA 12/900	1200	-	1100	170	900	1100	1500	670 x 1126 x 468	1080	-	5400	N	55
GHA 12/1050	1200	83	1100	170	1050	1250	1650	670 x 1276 x 468	1230	696	6200	N	85
GHA 12/1200	1200	-	1100	170	1200	1400	1800	670 x 1426 x 468	1380	-	7000	N	90

i Please note:
 - Heat up time is measured to 100°C below max, using an empty tube & insulation plugs
 - Measured with insulation plugs fitted

The GVA tube furnaces use free radiating wire elements embedded within the insulation of the furnace body. The benefit of this design is its flexibility; with the use of tube adapters the same furnace can be used with a variety of tube diameters.

This range of tube furnaces does not include an integral work tube and one must be selected as an additional item. The work tube length is dependent on the application eg for use with modified atmosphere or vacuum. This information can be found on pages 92-93.

The use of a separate work tube has the advantage of protecting the heating elements from damage or contamination.



GVA 12/600

Standard features

- 1200°C maximum operating temperature
- Accepts work tubes with outer diameters up to 170 mm
- Heated lengths of 300, 450, 600, 750, 900, 1050 or 1200 mm
- Removable tube adapters simplify working with different tube diameters
- Long life, rapid heating, resistance wire elements mounted in rigid, vacuum formed insulation modules
- Supplied with versatile stand for vertical, wall mounted and horizontal use
- Control module with 2 metre conduit to furnace
- Carbolite 301 PID controller with single ramp to setpoint and process timer

Options (specify these at time of order)

- Wide choice of tube diameters and materials is available: eg quartz, ceramic, metal. See pages 92-93 for tube materials and dimensions
- Over-temperature protection (recommended to protect valuable contents & for unattended operation)
- Available without stand (comprising control module & furnace body)
- Insulation plugs & radiation shields to prevent heat loss & improve uniformity
- Modified atmosphere and vacuum assemblies are available (see page 95)
- A range of sophisticated digital controllers, multi-segment programmers and data loggers is available. These can be fitted with RS232, RS485 or Ethernet communications (see pages 88-91)

Technical data

Model	Max temp (°C)	Max continuous operating temp (°C)	Dimensions: Max outer diameter accessory tube (mm)	Dimensions: Heated length (mm)	Dimensions: Furnace body length (mm)	Tube length for use in air (mm)	Tube length for use with modified atmosphere (mm)	Dimensions: External Furnace body (inc stand) H x W x D (mm)	Dimensions: Control module H x W x D (mm)	Dimensions: Clearance under furnace (mm)	Max power (W)	Ther-mo-couple type	Weight (kg)
GVA 12/300	1200	1100	170	300	480	500	900	1345 x 468 x 662	225 x 600 x 380	251 to 778	2300	N	73
GVA 12/450	1200	1100	170	450	630	650	1050	1418 x 468 x 662	225 x 600 x 380	177 to 702	3100	N	87
GVA 12/600	1200	1100	170	600	780	800	1200	1418 x 648 x 662	225 x 600 x 380	177 to 550	3900	N	95
GVA 12/750	1200	1100	170	750	930	950	1350	1793 x 468 x 662	225 x 600 x 380	177 to 777	4600	N	100
GVA 12/900	1200	1100	170	900	1080	1100	1500	1860 x 468 x 662	225 x 600 x 380	100 to 702	5400	N	110
GVA 12/1050	1200	1100	170	1050	1230	1250	1650	1943 x 468 x 662	225 x 600 x 380	26 to 627	6200	N	120
GVA 12/1200	1200	1100	170	1200	1380	1400	1800	2018 x 468 x 662	225 x 600 x 380	26 to 551	7000	N	130

i Please note:
- Heat up rate is measured to 100°C below max, using an empty tube & insulation plugs

The HTR furnaces combine in a laboratory scale unit many of the advantages of a fluidised bed reactor with those of a rotary kiln.

The sample is simultaneously heated and mixed under a controlled atmosphere. This overcomes the longer reaction times required in standard chamber or tube furnaces.



HTR 11/150

Standard features

- 1100 °C maximum operating temperature
- Developed in partnership with the Imperial College of Science & Technology, London
- Carbolite 301 PID controller with single ramp to setpoint and process timer
- Heating is provided by long life, rapid heating, resistance wire elements mounted in rigid, half cylindrical vacuum formed insulation modules
- Quartz reaction vessel included as standard
- The fluted internal surface of the quartz reactor ensures thorough mixing as the variable speed electric drive system oscillates the reactor tube through 315°
- A positive break safety interlock switch cuts power to the elements when the heating chamber is open
- Gas enters the reactor through a flexible silicon rubber tube
- A 30 mm flow meter for nitrogen is provided
- A single seal gasket directs the reactor exhaust into a removable stainless steel exhaust box from where a gas outlet allows piping to an extraction system

Options (specify these at time of order)

- Over-temperature protection (recommended to protect valuable contents & for unattended operation)
- Single or multiple flow meters for different gases
- Hydrogen detectors & gas safety system
- A range of sophisticated digital controllers, multi-segment programmers and data loggers is available. These can be fitted with RS232, RS485 or Ethernet communications (see pages 88-91)
- Optional inconel reactor

Technical data

Model	Max temp (°C)	Heat-up time (mins)	Max continuous operating temp (°C)	Cooling time with lid open (mins)	Dimensions: Reaction chamber dimensions (mm)	Dimensions: Reaction chamber capacity (ml)	Dimensions: Oscillation frequency per min	Dimensions: Rotation in each direction	Dimensions: External H x W x D (mm) lid down	Dimensions: External H x W x D (mm) lid open	Max power (W)	Holding power (W)	Thermo-couple type	Weight (kg)
HTR 11/75	1100	11	1000	15	75 x 100	50	1 to 8	315°	480 x 1140 x 550	800 x 1140 x 680	1500	400	K	40
HTR 11/150	1100	21	1000	15	150 x 200	700	1 to 8	315°	540 x 1300 x 900	950 x 1300 x 900	3000	1000	K	95

i Please note:
- Holding power is measured at the continuous operating temperature

The TZF horizontal 3-zone tube furnace range uses a wire element that is wound directly onto a fixed integral ceramic work tube.

The heated length is divided into 3 zones. An extended uniform zone in the mid-section of the work tube is achieved with the use of end zone controllers which track the centre zone temperature and compensate for the loss of heat from the tube ends.

This design provides a furnace which can be used without the need to purchase an accessory work tube.

However, should vacuum or a modified atmosphere be required, it is necessary to use a separate slide-in work tube in order to provide the required length needed to fit end seals.

Similarly, in some circumstances a work tube that has different physical or chemical properties to the fixed work tube may be required.



TZF 12/75/700

Standard features

- 1200 °C maximum operating temperature
- Provides a longer uniform zone than can be achieved in a single zone tube furnace
- End zone control is via back to back thermocouples
- Heated lengths of 400, 550, 700 or 900 mm
- Accept work tubes with outer diameters of 32 mm to 90 mm
- Horizontally mounted on control module base

Options (specify these at time of order)

- Insulation plugs & radiation shields to prevent heat loss & improve uniformity
- Modified atmosphere and vacuum assemblies are available (see page 95)
- Alternative mounting options are available (see page 39)
- 'Retransmission of Setpoint' control configuration to facilitate programmed cooling
- A range of sophisticated digital controllers, multi-segment programmers and data loggers is available. These can be fitted with RS232, RS485 or Ethernet communications (see pages 88-91)

Technical data

Model	Max temp (°C)	Heat-up time (mins)	Max continuous operating temp (°C)	Dimensions: Fixed tube inner diameter (mm)	Dimensions: Heated length (mm)	Dimensions: External H x W x D (mm)	Dimensions: Furnace body length (mm)	Uniform length ±5°C (mm)	Max power (W)	Holding power (W)	Thermocouple type	Weight (kg)
TZF 12/38/400	1200	25	1100	38	400	430 x 450 x 375	450	305	1300	300	N	20
TZF 12/38/850	1200	-	1100	38	850	430 x 900 x 375	900	-	2850	-	N	27
TZF 12/65/550	1200	45	1100	65	550	525 x 625 x 360	600	390	2000	600	N	38
TZF 12/75/700	1200	45	1100	75	700	525 x 775 x 360	750	540	3000	800	N	46
TZF 12/100/900	1200	120	1100	100	900	525 x 975 x 360	950	754	4150	1000	N	54

i Please note:

- Heat up rate is measured to 100°C below max, using an empty tube & insulation plugs
- Holding power is measured at the continuous operating temperature
- Maximum power and heat up time based on a 240 V supply

Three Zone Tube Furnaces

50 EHC, EVC, EZS and EVZ – Compact Modular 3-Zone Tube Furnaces

These 3-zone tube furnaces use free radiating wire elements embedded within the insulation of the furnace body. The benefit of this design is its flexibility; with the use of tube adapters the same furnace can be used with a variety of tube diameters. The furnaces are available with horizontal or vertical, split and non-split configuration.

The models EZS and EVZ comprise a furnace body which is hinged and split into two halves along its length. This makes exchange of work tubes easier and also enables the furnace to be used with reactors or work tubes where end flanges would make insertion into a non-split furnace difficult.

Excellent uniformity results from division of the heated length into 3-zones each with its own controller and thermocouple.

This range of tube furnaces does not include an integral work tube and one must be selected as an additional item. The work tube length is dependent on the application eg for use with modified atmosphere or vacuum; this information can be found on pages 92-93.

The use of a separate work tube has the advantage of protecting the heating elements from damage or contamination.

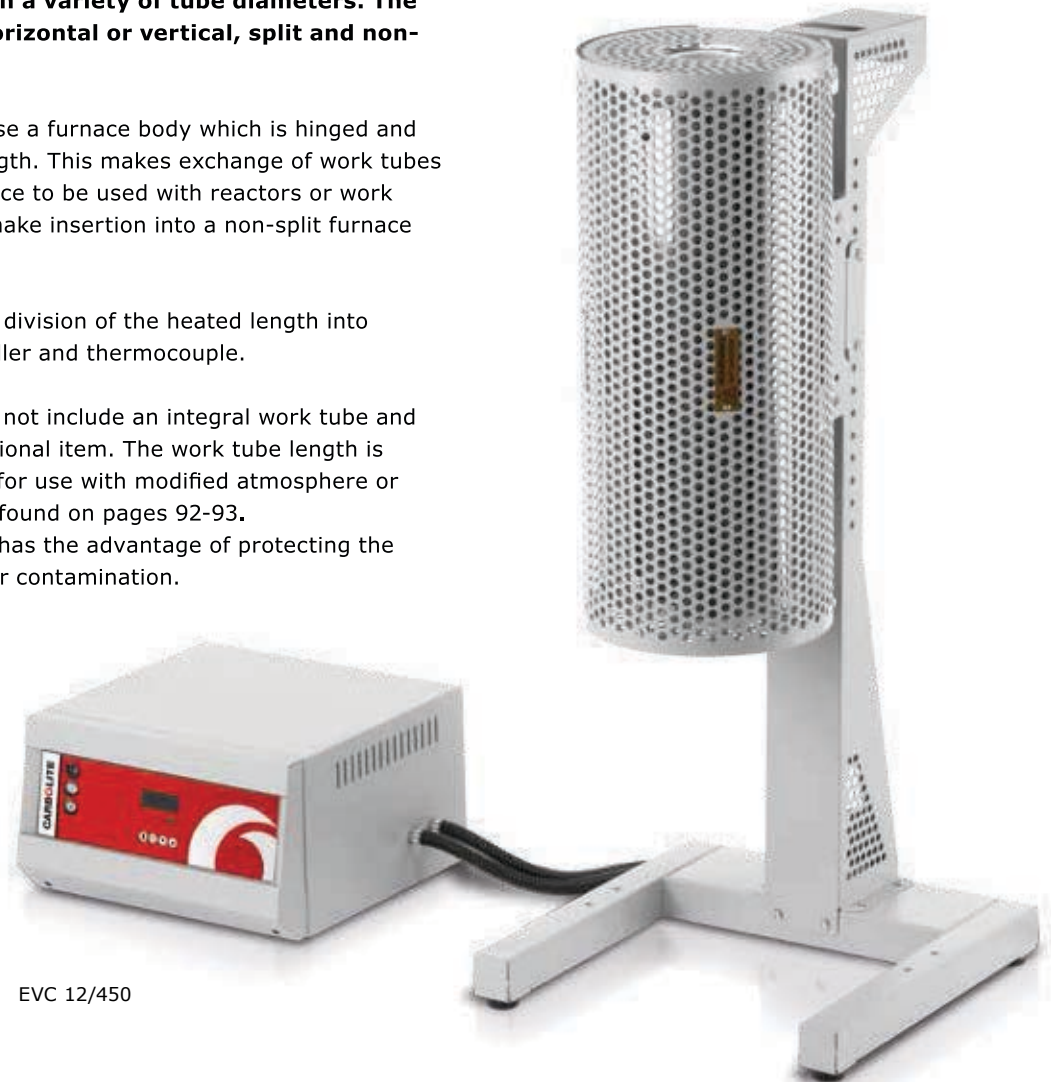

EVC 12/450

Standard features

- 1200 °C maximum operating temperature
- 450 or 600 mm heated lengths
- Provides a longer uniform zone than can be achieved in a single zone tube furnace
- Accepts work tubes with outer diameters up to 60mm
- Wire elements in high quality vacuum formed insulation ensure fast heat up, excellent temperature uniformity and short cool down times
- Models EHC, EZS: Horizontal configuration
- Models EVC, EVZ: Vertical configuration (can also be used horizontally)
- Models EVC, EVZ: Control module with 2 metre conduit to furnace
- Carbolite 301 digital PID controller with single ramp to setpoint, digital display and process timer
- Outer mesh guard ensures operator safety

Model EVC: Angle adjustment option for flexible operation. Also available for EVA models (see page 43)



Options (specify these at time of order)

- Model EVC: Angle adjustment option allows horizontal and multi-angle configuration
- Insulation plugs, gas tight end seals and vacuum connections available
- A range of sophisticated digital controllers, multi-segment programmers and data loggers is available. These can be fitted with RS232, RS485 or Ethernet communications (see pages 88-91)
- Over-temperature protection (recommended to protect valuable contents & for unattended operation)
- Wide choice of tube diameters and materials is available: eg quartz, ceramic, metal. See pages 92-93 for tube materials and dimensions
- 'Retransmission of Setpoint' control configuration to facilitate programmed cooling

Technical data

Model	Configuration		Max temp (°C)	Heat up time (mins)	Dimensions: Max outer ø accessory tube (mm)	Heated length (mm)	Tube length for use in air (mm)	Tube length for use with modified atmosphere (mm)	Dimensions: External H x W x D (mm)	Quartz tube uniform length ±5°C @800°C (mm)	Max power (W)	Thermo-couple Type	Weight (kg)
EHC 12/450	Non-Split	horizontal	1200	55	60	450	600	900	560 x 615 x 390	-	2000	N	20
EHC 12/600	Non-Split	horizontal	1200	55	60	600	750	1050	560 x 765 x 390	500	2520	N	25
EVC 12/450	Non-Split	vertical	1200	58	60	450	600	900	1040 x 545 x 545	-	2000	N	30
EVC 12/600	Non-Split	vertical	1200	58	60	600	750	1050	1160 x 545 x 545	490	2520	N	35
EZS 12/450	Split	horizontal	1200	55	60	450	600	900	560 x 615 x 390	-	2000	N	21
EZS 12/600	Split	horizontal	1200	55	60	600	750	1050	560 x 765 x 390	500	2520	N	26
EVZ 12/450	Split	vertical	1200	58	60	450		900	1040 x 545 x 545	-	2000	N	31
EVZ 12/600	Split	vertical	1200	58	60	600		1050	1160 x 545 x 545	490	2520	N	36

i Please note:
 - Heat up rate is measured to 100°C below maximum, using an empty work tube and insulation plugs
 - Holding power is measured at continuous operating temperature

- Maximum continuous operating temperature is 100°C below maximum temperature
 - Models EVC and EVZ dimensions excluding control box (225 x 570 x 390 mm)

Three Zone Tube Furnaces

52

HZS – Horizontal Split 3-Zone Tube Furnaces

The HZS tube furnaces use free radiating wire elements embedded within the insulation of the furnace body. The benefit of this design is its flexibility; with the use of tube adapters the same furnace can be used with a variety of tube diameters.

These furnaces comprise a furnace body which is hinged and split into two halves along its length. This makes exchange of work tubes easier and also enables the furnace to be used with reactors or work tubes where end flanges would make insertion into a non-split furnace difficult.

Excellent uniformity results from division of the heated length into 3-zones each with its own controller and thermocouple. This range of tube furnaces does not include an integral work tube and one must be selected as an additional item. The work tube length is dependent on the application eg for use with modified atmosphere or vacuum. This information can be found on pages 92-93.

The use of a separate work tube has the advantage of protecting the heating elements from damage or contamination.



HZS 12/900

Standard features

- 1200 °C maximum operating temperature
- Accepts work tubes with outer diameters up to 110 mm
- Heated lengths of 600 mm or 900 mm
- Horizontal furnaces with a separate control module on a 2 metre conduit
- Furnace splits into two halves to accommodate work tubes or samples fixed into a test rig
- Wire elements in high quality vacuum formed insulation ensure fast heat up, excellent temperature uniformity and short cool down times
- Carbolite 301 digital PID controller with single ramp to setpoint, digital display and process timer
- End zone control is via back to back thermocouples
- End zones of 150 mm

Options (specify these at time of order)

- Three equal length zones
- Insulation plugs, gas tight end seals and vacuum connections available
- Wide choice of tube diameters and materials is available: eg quartz, ceramic, metal. See pages 92-93 for tube materials and dimensions
- Over-temperature control; recommended for unattended operation and to protect a valuable load
- Available with 'L' stand for vertical and horizontal use
- Control module on longer 6 metre conduit
- A range of sophisticated digital controllers, multi-segment programmers and data loggers is available. These can be fitted with RS232, RS485 or Ethernet communications (see pages 88-91)
- If programmed cooling is required, then programmable controllers capable of retransmission of setpoint can be supplied

Technical data

Model	Max temp (°C)	Heat-up time (mins)	Dimensions: Max outer diameter accessory tube (mm)	Dimensions: Heated length (mm)	Dimensions: Furnace body length (mm)	Recommended tube length for use in air (mm)	Recommended tube length for use with modified atmosphere (mm)	Dimensions: External Furnace H x W x D (mm)	Dimensions: Control module H x W x D (mm)	Uniform length ±5°C (mm)	Max power (W)	Holding power (W)	Thermocouple type	Weight (kg)
HZS 12/600	1200	45	110	600	750	750	1050	350 x 750 x 410	225 x 570 x 380	500	3000	1000	N	40
HZS 12/900	1200	45	110	900	1050	1050	1350	350 x 1050 x 410	225 x 570 x 380	750	4500	1400	N	65

i Please note:

- Holding power is measured at the continuous operating temperature
- Heat up rate is measured to 100°C below max, using an empty tube & insulation plugs

- Uniform length measured with insulation plugs fitted
- Maximum continuous operating temperature is 100°C below maximum temperature

The TVS tube furnaces use free radiating wire elements embedded within the insulation of the furnace body. The benefit of this design is its flexibility; with the use of tube adapters the same furnace can be used with a variety of tube diameters.

These furnaces comprise a furnace body which is hinged and split into two halves along its length. This makes exchange of work tubes easier and also enables the furnace to be used with reactors or work tubes where end flanges would make insertion into a non-split furnace difficult. This design is particularly suitable for incorporation into extension test and creep test apparatus.

This range of tube furnaces does not include an integral work tube and one must be selected as an additional item. The work tube length is dependent on the application eg for use with modified atmosphere or vacuum and this information can be found on pages 92-93. The use of a separate work tube has the advantage of protecting the heating elements from damage or contamination. The 'near-hinge' format is standard, an alternative option that can be specified at the time of purchase is the 'far-hinge' format, where the pivot of hinges is further from the centre line of the furnace to enable a wider opening action.



TVS 12/600

Standard features

- 1200°C maximum operating temperature
- Accepts work tubes with outer diameters up to 110 mm
- Heated lengths of 600, 900 mm
- Furnace splits into two halves and accommodates work tubes or samples fixed into a test rig
- Wire elements in high quality vacuum formed insulation ensure fast heat up, excellent temperature uniformity and short cool down times
- Supplied in 'near-hinge' configuration complete with stand
- Vertical furnace with a separate control module on a 2 metre conduit (for vertical use only)
- Carbolite 301 digital PID controller with single ramp to setpoint, digital display and process timer
- End zone control is via back to back thermocouples
- End zones of 150 mm

Options (specify these at time of order)

- Three equal length zones
- Insulation plugs, gas tight end seals and vacuum connections available
- 'Far-hinge' configuration providing wider opening of furnace body
- Wide choice of tube diameters and materials is available: eg quartz, ceramic, metal. See pages 92-93 for tube materials and dimensions.
- Over temperature control; recommended for unattended operation and to protect a valuable load
- Control module on longer 6 metre conduit
- A range of sophisticated digital controllers, multi-segment programmers and data loggers is available. These can be fitted with RS232, RS485 or Ethernet communications (see pages 88-91)

Technical data

Model	Max temp (°C)	Heat-up time (mins)	Dimensions: Max outer diameter accessory tube (mm)	Dimensions: Heated length (mm)	Dimensions: Furnace body length (mm)	Recommended tube length for use in air (mm)	Recommended tube length for use with modified atmosphere (mm)	Dimensions: External Furnace H x W x D (mm)	Dimensions: Control module H x W x D (mm)	Uniform length ±5°C (mm)	Max power (W)	Holding power (W)	Thermocouple type	Weight (kg)
TVS 12/600	1200	45	110	600	750	950	1050	1040 x 500 x 495	225 x 570 x 380	500	3000	1100	N	34
TVS 12/900	1200	45	110	900	1050	1250	1350	1340 x 500 x 675	225 x 570 x 380	750	4500	1450	N	44

i Please note:

- Heat up time is measured to 100°C below max, using an empty tube & insulation plugs
- Uniform length measured with insulation plugs fitted
- Maximum continuous operating temperature is 100°C below maximum temperature

Three Zone Tube Furnaces

54 **GHC – Modular Horizontal 3-Zone Tube Furnaces**

The **GHC tube furnaces use free radiating wire elements embedded within the insulation of the furnace body. The benefit of this design is its flexibility; with the use of tube adapters the same furnace can be used with a variety of tube diameters.**

The heated length is divided into 3-zones. An extended uniform zone in the mid-section of the work tube is achieved with the use of end zone controllers which track the centre zone temperature and compensate for the loss of heat from the tube ends.

This range of tube furnaces does not include an integral work tube and one must be selected as an additional item. The work tube length is dependent on the application eg for use with modified atmosphere or vacuum and this information can be found on pages 92-93.



GHC 12/750

Standard features

- 1200°C maximum operating temperature
- Provides a longer uniform zone than can be achieved in a single zone tube furnace
- Heated lengths of 450, 600, 750, 900, 1050, or 1200 mm
- Accepts work tubes with outer diameter up to 170 mm
- End zone control is via back to back thermocouples
- Horizontal configuration with furnace mounted onto control module
- Carbolite 301 PID controller with single ramp to setpoint & process timer
- End zones 150 mm long

Options (specify these at time of order)

- Wide choice of tube diameters and materials is available: eg quartz, ceramic, metal. See pages 92-93 for tube materials and dimensions
- End zones 300 mm long
- Insulation plugs & radiation shields to prevent heat loss & improve uniformity
- Modified atmosphere and vacuum assemblies are available (see page 95)
- A range of sophisticated digital controllers, multi-segment programmers and data loggers is available. These can be fitted with RS232, RS485 or Ethernet communications (see pages 88-91)
- 'Retransmission of Setpoint' control configuration to facilitate programmed cooling
- Alternative mounting options are available (see page 39)

Technical data

Model	Max temp (°C)	Heat-up time (mins)	Max continuous operating temp (°C)	Dimensions: Max outer diameter accessory tube (mm)	Dimensions: Heated length (mm)	Tube length for use in air (mm)	Tube length for use with modified atmosphere (mm)	Dimensions: External H x W x D (mm)	Dimensions: Furnace body length (mm)	Uniform length ±5°C (mm)	Max power (W)	Holding power (W)	Thermocouple type	Weight (kg)
GHC 12/450	1200	98	1100	170	450	650	1050	672 x 676 x 468	630	300	3100	1500	N	37
GHC 12/600	1200	64	1100	170	600	800	1200	672 x 827 x 468	780	440	3900	1800	N	40
GHC 12/750	1200	74	1100	170	750	950	1350	672 x 976 x 468	930	500	4600	2200	N	51
GHC 12/900	1200	79	1100	170	900	1100	1500	672 x 1126 x 468	1080	640	5400	2800	N	55
GHC 12/1050	1200	100	1100	170	1050	1250	1650	672 x 1276 x 468	1230	880	6200	2850	N	85
GHC 12/1200	1200	-	1100	170	1200	1400	1800	672 x 1426 x 468	1380	-	7000	3100	N	90

i Please note:

- Heat up rate is measured to 100°C below max, using an empty tube & insulation plugs
- Holding power is measured at the continuous operating temperature
- Uniform length measured with insulation plugs fitted

The GVC tube furnaces use free radiating wire elements embedded within the insulation of the furnace body. The benefit of this design is its flexibility; with the use of tube adapters the same furnace can be used with a variety of tube diameters. The heated length is divided into 3-zones.

An extended uniform zone in the mid-section of the work tube is achieved with the use of end zone controllers which track the centre zone temperature and compensate for the loss of heat from the tube ends.

This range of tube furnaces does not include an integral work tube and one must be selected as an additional item. The work tube length is dependent on the application eg for use with modified atmosphere or vacuum This information can be found on pages 92-93.

The use of a separate work tube has the advantage of protecting the heating elements from damage or contamination.



GVC 12/750

Standard features

- 1200 °C maximum operating temperature
- Provides a longer uniform zone than can be achieved in a single zone tube furnace
- Heated lengths of 450, 600, 750, 900, 1050, or 1200 mm
- Accepts work tubes with outer diameter up to 170 mm
- End zone control is via back to back thermocouples
- Supplied with versatile stand for vertical, wall mounted and horizontal use
- Carbolite 301 PID controller with single ramp to setpoint & process timer
- End zones 150 mm long

Options (specify these at time of order)

- Wide choice of tube diameters and materials is available: eg quartz, ceramic, metal. See pages 92-93 for tube materials and dimensions
- End zones 300 mm long
- Over-temperature protection recommended to protect valuable contents & for unattended operation)
- Modified atmosphere and vacuum assemblies are available (see page 95)
- A range of sophisticated digital controllers, multi-segment programmers and data loggers is available. These can be fitted with RS232, RS485 or Ethernet communications (see pages 88-91)
- Retransmission of setpoint control configuration to facilitate programmed cooling
- Available without stand (control module & furnace body only)
- Control module on longer 6 metre conduit

Technical data

Model	Max temp (°C)	Heat-up time (mins)	Dimensions: Max outer diameter accessory tube (mm)	Dimensions: Heated length (mm)	Dimensions: Furnace body length (mm)	Tube length for use in air (mm)	Tube length for use with modified atmosphere (mm)	Dimensions: External Furnace H x W x D (mm)	Dimensions: Control module H x W x D (mm)	Clearance under furnace H (mm)	Uniform length ±5°C (mm)	Max power (W)	Holding power (W)	Thermocouple type	Weight (kg)
GVC 12/450	1200	75	170	450	630	650	1050	1418 x 468 x 662	225 x 600 x 380	177 to 702	300	3100	1500	N	87
GVC 12/600	1200	80	170	600	780	800	1200	1418 x 468 x 662	225 x 600 x 380	177 to 550	440	3900	1800	N	95
GVC 12/750	1200	92	170	750	930	950	1350	1793 x 468 x 662	225 x 600 x 380	177 to 777	500	4600	2200	N	100
GVC 12/900	1200	111	170	900	1080	1100	1500	1860 x 468 x 662	225 x 600 x 380	100 to 702	640	5400	2800	N	110
GVC 12/1050	1200	122	170	1050	1230	1250	1650	1943 x 468 x 662	225 x 600 x 380	26 to 627	880	6200	2800	N	120
GVC 12/1200	1200	81	170	1200	1380	1400	1800	2018 x 468 x 662	225 x 600 x 380	26 to 551	1015	7000	3100	N	130

i Please note:

- Heat up time is measured to 100°C below max, using an empty tube & insulation plugs
- Maximum continuous operating temperature is 100°C below maximum temperature
- Holding power is measured at the continuous operating temperature

- Uniform length measured with insulation plugs fitted

MTT – Carbon-14 and Tritium Furnaces

This apparatus uses catalyst assisted combustion techniques to give a clean and precise approach to extracting carbon-14 & organically bound tritium or 'fixed tritium', eg tritium contained in concretes, steels and graphites, as well as 'free water'.

A catalyst is used to ensure complete combustion of all thermal decomposition products. These are captured for liquid scintillation assay. This technique gives greater confidence of complete combustion than 'wet oxidation' techniques and avoids coloured contamination of scintillation media by botanical samples. Computer control enables remote operation of multiple or individual units even in hazardous areas.



MTT 12/38/850

Standard features

- 2-zone tube furnace configured for capture by combustion of organically bound carbon-14 and tritium
- Large sample capacity up to 20 ml provides accurate determinations
- Originally developed in partnership with AEA Technology
- 2 quartz glass work tube assemblies
- 6 combustion boats
- Three sets of glass gas bubblers (12 in total)
- All connectors including the molecular sieve waste aerosol trap
- Unique catalyst optimisation manifold
- 6 copper wire catalysts
- 3508P1 20 segment programmable temperature control for sample specific combustion protocols
- Over-temperature protection of both heated zones
- RS485 communications & control
- Eurotherm iTools allows software storage & recall of specific sample protocols
- Free from plastic or rubber components into which tritium can migrate
- A comprehensive process instruction manual

Options (specify these at time of order)

- Additional sets of bubblers (sets of 4)
- Additional sets of combustion boats (sets of 6)
- Additional work tubes
- Additional copper catalyst (sets of 3)

Technical data

Model	Max temp (°C)	Dimensions: Heated length (mm)	Dimensions: External H x W x D (mm)	Dimensions: Furnace body length (mm)	Max power (W)	Thermocouple type	Weight (kg)	Power supply
MTT 12/38/850	1200	850	430 x 900 x 375	900	3100	N	60	220 V - 240 V, 50 - 60 Hz, single phase

i Please note:
- Continuous operating temperature is 100°C below maximum temperature

The HVTT high vacuum turbo-molecular tube furnaces are available in three standard sizes. A range of tube lengths and diameters is available.

These units are often the starting point for additional customisation such as automated control of gate valves, gas purge, back-fill systems and co-ordinated control of roughing pump with the turbo-molecular high vacuum pump.

A higher temperature range at 1500°C is also available – please see page 73.



HVTT 12/80/700

Standard features

- 1200 °C maximum operating temperature
- Capable of 10⁻⁵ mbar vacuum in a clean empty work tube
- Supplied with work tube inner diameters of 50, 60 and 80 mm
- Heated lengths of 550 mm and 700 mm
- Vacuum provided by oil-free scroll pump & turbo-molecular pump
- Cooling water failure alarm
- Manually operated roughing / backing valve
- Pirani gauge low vacuum monitor
- Penning gauge high vacuum monitor
- Work tube connects to the vacuum system via stainless steel connection
- Access to the work tube is via a removable stainless steel vacuum flange
- Radiation shields at both ends of the work tube maintain uniformity without reducing pump speeds
- All controls are mounted within the base unit

Options (specify these at time of order)

- Over-temperature protection (recommended to protect valuable contents & for unattended operation)
- A range of sophisticated digital controllers, multi-segment programmers and data loggers is available. These can be fitted with RS232, RS485 or Ethernet communications
- Custom built models including a variety of gas backfill systems, automatic & semi-automatic vacuum systems and 3-zone control for improved uniformity is available

Technical data

Model	Max temp (°C)	Dimensions: Worktube inner diameter (mm)	Dimensions: Heated length (mm)	Dimensions: External H x W x D (mm)	Max power (W)	Holding power (W)	Thermocouple type
HVTT 12/50/550	1200	50	550	1450 x 1700 x 600	2000	1600	N
HVTT 12/60/700	1200	60	700	1450 x 1700 x 600	3000	1800	N
HVTT 12/80/700	1200	80	700	1450 x 1700 x 600	3500	2800	N

i Please note:
 - Holding power is measured at the continuous operating temperature
 - Continuous operating temperature is 100°C below maximum temperature

PTC – Thermocouple Calibration Furnaces

The PTC thermocouple calibration furnace is designed to provide a high stability portable heat source for the calibration of thermocouples using the comparison method.

Standard features

- 1200 °C maximum operating temperature
- High stability heat source with temperature range 400 to 1150 °C
- Accepts thermocouples up to 7.5 mm diameter
- Thermocouple is inserted & compared to the PTC 12/20's displayed temperature
- PID temperature control & separate temperature display to 1.0 °C resolution
- The special work tube design provides better temperature uniformity than is typical for a furnace of this size
- The metallic work tube is earthed for operator safety when testing metal sheathed mineral insulated mineral thermocouples
- Rapid heat up and stabilisation makes it ideal for use in the laboratory or on site
- Portable & self-contained



PTC 12/20/150

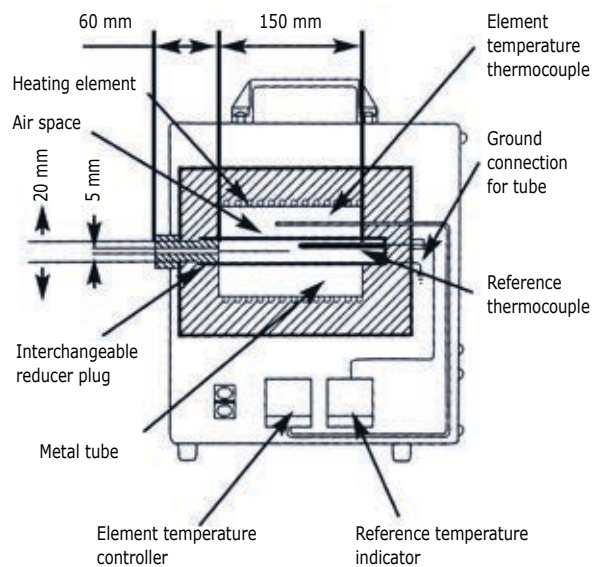

Options (specify these at time of order)

- Factory calibration certificate stating the error between the workspace temperature & the displayed value at 700 °C, 900 °C & 1100 °C
- A UKAS traceable calibration certificate for customer defined setpoints is available
- A UKAS traceable thermocouple is available

Technical data

Model	Max temp (°C)	Heat-up time to 1150 °C (mins)	Temperature range (°C)	Stability (±°C)	Heated length (mm)	Dimensions: Fixed tube inner diameter (mm)	Dimensions: External H x W x D (mm)	Max power (W)	Thermocouple type	Weight (kg)
PTC 12/20/150	1200	20	400 to 1150	0.5 @ 1150 °C	150	20	399 x 310 x 225	1100	N	8.8

i Please note:
- Continuous operating temperature is 50 °C below maximum temperature

The CF cupellation furnaces are designed for the cupellation, or fire assay test, of precious metals, which is a standard test method used to determine their purity.

The furnaces meet the Hallmarking requirements specified by the Convention on the Control and Marking of Articles of Precious Metals (known also as "Precious Metals Convention", "Hallmarking Convention" or "Vienna Convention").

The test method produces hazardous vapours. When used within a suitable fume management system, the cupellation furnaces are designed to handle the vapours without exposing the operator to these hazards. The design of the cupellation furnace range ensures protection from the corrosive environment which would damage a conventional furnace.

Carbolite also offers a range of smelting/melting furnaces (see page 75).

CF 24



Standard features

- 1200 °C maximum operating temperature
- Designed for testing using the cupellation method to ISO11426:1999 the standard test method used by the UK Assay Office, a reference quantitative assay method by the International Hallmark Convention
- The airflow, controlled by an adjustable valve, is preheated before entering the work chamber
- Silicon carbide elements mounted above & below the chamber provide even heating of cupels, have good resistance to thermal shock and offer extended working life at high temperatures
- Silicon carbide lined roof and hearth protect the heating elements and resist the corrosive fumes emitted during the cupellation process
- Fumes are extracted through an insulated exhaust duct, with a removable container to collect condensed lead
- Up & away counterbalanced vertically opening door fitted with observation hole
- Element over-temperature protection controller
- Fitted with 7 day, 24 hour time-switch

Technical data

Model	Max temp (°C)	Maximum continuous operating temp (°C)	Dimensions: Internal H x W x D (mm)	Dimensions: External H x W x D (mm)	Charge capacity of no. 8 cupels	Charge capacity of no. 6 cupels	Max power (W)	Thermocouple type	Power supply		
									Volt	Phase	Ampere per phase
CF 15	1200	1200	125 x 215 x 270	1050 x 950 x 1070 (Bench-mounted) 225 x 600 x 380 (Separate control module)	15	24	9000	R	200 - 240	Single phase	68
									380 - 415	3 phase + N	23
									200 - 240	3 phase delta	40
CF 24	1200	1200	200 x 250 x 340	2050 x 1000 x 1200 (Floor-standing)	24	32	13000	R	200 - 240	Single phase	87
									380 - 415	3 phase + N	28
									200 - 240	3 phase delta	50
CF 50	1200	1200	230 x 350 x 500	2095 x 1050 x 1050 (Floor-standing)	50	72	20000	R	380 - 415	3 phase + N	43
									200 - 240	3 phase delta	74
									440	3 phase + N	43

GPC – General Purpose Chamber Furnaces

The GPC general purpose chamber furnaces include both bench mounted and larger floor-standing models. Available at 1200 °C and 1300 °C, capacities range from 36 to 200 litres depending on the temperature.

Standard features

- 1200 °C or 1300 °C maximum operating temperature
- 36, 65, 131 or 200 litre chamber volumes
- Free radiating coiled wire elements
- Low thermal mass insulation for fast response & energy efficiency
- Up & away door keeps heated surface away from the user
- Carbolite 301 PID controller with single ramp to setpoint & process timer
- Hard wearing refractory hearth plate resists damage & supports heavier loads
- Heating elements are easily serviced



GPC 12/36

Options (specify these at time of order)

- Over-temperature protection (recommended to protect valuable contents & for unattended operation)
- A range of sophisticated digital controllers, multi-segment programmers and data loggers is available. These can be fitted with RS232, RS485 or Ethernet communications (see pages 88-91)
- A range of Inconel retorts to work with modified atmospheres up to 1100 °C
- AMS 2750E Nadcap compatible models are available for aerospace applications
- Various loading and unloading management options can be supplied

Technical data

Model	Max temp (°C)	Max continuous operating temp (°C)	Heat-up time (mins)	Dimensions: Internal H x W x D (mm)	Dimensions: External H x W x D (mm) H (door open)	Volume (litres)	Max power (W)	Thermocouple type	Weight (kg)
GPC 12/36	1200	1100	37	250 x 320 x 450	810 x 690 x 780 (1105) (Bench-top)	36	9000	R	100
GPC 12/65	1200	1100	40	278 x 388 x 595	885 x 780 x 945 (1245) (Bench-top)	65	14000	R	165
GPC 12/131	1200	1100	150	350 x 500 x 750	1652 x 1110 x 1280 (2310) (Floor-standing)	131	18000	R	400
GPC 12/200	1200	1100	-	400 x 600 x 900	1702 x 1350 x 1350 (2410) (Floor-standing)	200	24000	R	518
GPC 13/36	1300	1200	47	250 x 320 x 450	810 x 690 x 780 (1105) (Bench-top)	36	9000	R	120
GPC 13/65	1300	1200	45	278 x 388 x 595	885 x 780 x 945 (1245) (Bench-top)	65	14000	R	165
GPC 13/131	1300	1200	-	350 x 500 x 750	1652 x 1110 x 1280 (2310) (Floor-standing)	131	18000	R	400

i Please note:
 - Heat up time is measured to 100 °C below max, using an empty chamber
 - Holding power is measured at continuous operating temperature

The robust construction of the LCF large chamber furnaces makes them ideal for applications such as the heat treatment of steels and alloy, ceramics sintering and aerospace heat treatment.

The LCF range is often customised in order to precisely meet the user's requirements. This range also provides a foundation upon which a wide range of custom modifications can be added. Typical examples of which are the more sophisticated control systems and data recording that is required for applications such as AMS 2750E heat treatment under Nadcap. Solutions are available to handle heavier loads or assist in loading and unloading the furnace, or larger chamber sizes than are offered in the standard range.

Standard features

- 1200 °C & 1400 °C maximum temperatures
- Carbolite 301 controller with single ramp to setpoint and process timer
- Excellent temperature uniformity and control
- Robust construction using hollow steel section & zinc coated steel sheet
- Double skin construction ensures safe outer case temperature
- Manually operated vertically opening door keeps the hot face away from the operator
- Low thermal mass insulation for high energy efficiency
- Hard wearing silicon carbide tiled hearth
- 1200 °C range heated by heavy gauge wire elements in roof and below the hearth
- 1400 °C range heated by silicon carbide elements in roof and below the hearth
- Safety door interlock isolates power from the elements whenever the door is opened



Customised
3-zone LCF 12/560

Options (specify these at time of order)

- A range of sophisticated digital controllers, multi-segment programmers and data loggers is available. These can be fitted with RS232, RS485 or Ethernet communications (see pages 88-91)
- Pneumatically or electrically operated doors
- A range of retorts can be supplied for using modified atmospheres up to 1000 °C
- Remote control module
- Designs for compliance with AMS 2750E (Nadcap) and other industry standards

Technical data

Model	Max temp (°C)	Max continuous operating temp (°C)	Dimensions: Internal H x W x D (mm)	Dimensions: External H x W x D (mm) H (door open)	Volume (litres)	Max power (W)	Thermocouple type
LCF 12/202	1200	1150	300 x 600 x 1120	2310 x 1180 x 1590	202	24000	R
LCF 12/405	1200	1150	450 x 750 x 1200	2560 x 1440 x 1750	405	35000	R
LCF 12/560	1200	1150	500 x 750 x 1500	2700 x 1500 x 2300	560	45000	R
LCF 12/675	1200	1150	500 x 750 x 1800	2700 x 1500 x 2600	675	60000	R
LCF 12/720	1200	1150	600 x 1000 x 1200	2950 x 1575 x 1810	720	60000	R
LCF 14/125	1400	1400	250 x 500 x 1000	2310 x 1340 x 1650	125	30000	R
LCF 14/350	1400	1400	400 x 760 x 1130	2545 x 1549 x 1800	350	48000	R
LCF 14/480	1400	1400	500 x 800 x 1200	2560 x 1650 x 1900	480	60000	R
LCF 14/725	1400	1400	500 x 720 x 1790	2620 x 1480 x 2470	725	60000	R

Products in this section include an extensive range of chamber and tube furnaces with maximum operating temperatures up to 1800 °C. Specialist models include bottom loading furnaces.

1300 °C - 1800 °C



Temperature Range 1300 °C – 1800 °C	Models	Page
Chamber Furnaces Selection Guide		28
Universal Chamber Furnaces	RHF, HTF, BLF	64
Tube Furnaces Selection Guide		38
Universal Tube Furnaces	STF, VST 17, CTF 17 & 18, TZF	68
Application Specific Furnaces	HVTT, CDF, SCF	74
Product Configurations		88

RHF – High Temperature Chamber Furnaces

The RHF range of silicon carbide heated high temperature chamber furnaces comprises four chamber sizes, each available with three maximum operating temperatures of 1400 °C, 1500 °C and 1600 °C.

Robust construction and high quality elements provide rapid heating rates (typically reaching 1400 °C in under 40 minutes) and a long reliable working life.

Standard features

- 1400 °C, 1500 °C or 1600 °C maximum operating temperature
- 3, 8, 15 or 35 litre chamber volumes
- Silicon carbide heating elements provide long life and are able to withstand the stresses of intermittent operation
- Carbolite 301 PID controller with single ramp to setpoint & process timer
- Hard wearing refractory brick door surround and silicon carbide hearth
- Low thermal mass insulation for energy efficiency & rapid heating & cooling



RHF 15/3

Options (specify these at time of order)

- Over-temperature protection (recommended to protect valuable contents & for unattended operation)
- A range of sophisticated digital controllers, multi-segment programmers and data loggers is available. These can be fitted with RS232, RS485 or Ethernet communications (see pages 88-91)



RHF 16/35

Power supplies for silicon carbide furnaces

A characteristic of the control systems used with silicon carbide elements results in a power supply which will be larger than expected eg RHF 14/3 at 4500 W =

- Single phase / 200 – 240 V / 30 A or
- 2 phase / 380 – 415 V / 15 A per phase.

Please see the specification table for power supply details.

Technical data

Model	Max temp (°C)	Heat-up time (mins)	Dimensions: Internal H x W x D (mm)	Dimensions: External H x W x D (mm) H (door open)	Volume (litres)	Holding power (W)	Max power (W)	Thermocouple type	Weight (kg)	Power supply		
										Volt	Phase	Ampere per phase
RHF 14/3	1400	33	120 x 120 x 205	655 x 435 x 610 (905) (Bench-top)	3	1900	4500	R	42	200 – 240	single phase	30
										380 – 415	2 phase + N	15
RHF 14/8	1400	22	170 x 170 x 270	705 x 505 x 675 (990) (Bench-top)	8	3200	8000	R	64	200 – 240	single phase	50
										380 – 415	2 phase + N	25
RHF 14/15	1400	35	220 x 220 x 310	810 x 690 x 780 (1105) (Bench-top)	15	2900	10000	R	125	200 – 240	single phase	62
										380 – 415	3 phase + N	22
										200 – 220	3 phase delta	38
RHF 14/35	1400	38	250 x 300 x 465	885 x 780 x 945 (1245) (Bench-top)	35	6000	16000	R	179	380 – 415	3 phase + N	35
										200 – 220	3 phase delta	60
										440 – 480	3 phase no N	35
RHF 15/3	1500	45	120 x 120 x 205	655 x 435 x 610 (905) (Bench-top)	3	2000	4500	R	46	200 – 240	single phase	36
										380 – 415	2 phase + N	18
RHF 15/8	1500	40	170 x 170 x 270	705 x 505 x 675 (990) (Bench-top)	8	3500	8000	R	61	380 – 415	3 phase + N	17.5
										200 – 220	3 phase delta	30
										200 – 208	3 phase delta	38
										380 – 415	3 phase delta	17.5
RHF 15/15	1500	46	220 x 220 x 310	810 x 690 x 780 (1105) (Bench-top)	15	3000	10000	R	125	200 – 240	single phase	75
										380 – 415	3 phase + N	25
										230 – 240	3 phase delta	43
RHF 15/35	1500	46	250 x 300 x 465	885 x 780 x 945 (1245) (Bench-top)	35	6200	16000	R	178	380 – 415	3 phase + N	35
										200 – 240	3 phase delta	60
										380 – 415	3 phase no N	35
										440 – 480	3 phase + N	35
RHF 16/3	1600	42	120 x 120 x 205	655 x 435 x 610 (905) (Bench-top)	3	2300	4500	R	42	200 – 240	single phase	36
										380 – 415	2 phase + N	18
										200 – 240	3 phase delta	30
RHF 16/8	1600	35	170 x 170 x 270	705 x 505 x 675 (990) (Bench-top)	8	4000	8000	R	61	380 – 415	3 phase + N	18
										220 – 240	3 phase delta	29
										200 – 208	3 phase delta	34
										380 – 415	3 phase no N	18
										440 – 480	3 phase no N	18
RHF 16/15	1600	58	220 x 220 x 310	810 x 690 x 780 (1105) (Bench-top)	15	3500	10000	R	140	200 – 240	single phase	73
										380 – 415	3 phase + N	25
										200 – 240	3 phase delta	42
										440 – 480	3 phase + N	25
RHF 16/35	1600	56	250 x 300 x 465	1530 x 900 x 1020 (1885) (Floor-standing)	35	7000	16000	R	270	380 – 415	3 phase + N	40
										220 – 240	3 phase delta	62
										380 – 415	3 phase no N	37
										440 – 480	3 phase + N	40

i Please note:

- Maximum continuous operating temperature is 100°C below maximum temperature
- Heat up time is measured to 100°C below max, using an empty chamber
- Holding power is measured at continuous operating temperature

HTF – High Temperature Laboratory Chamber Furnaces

The HTF high temperature chamber furnace range comprises 1700°C and 1800°C models.

The two smaller models in each temperature are bench mounted and the larger units are floor-standing. These furnaces may be customised in order to satisfy specific customer requirements, eg the addition of catalytic afterburners for ceramic binder burn-off applications.

Standard features

- 1700°C & 1800°C maximum operating temperatures
- From 4 to 27 litre capacities
- High quality molybdenum disilicide heating elements
- Up & away parallel opening door keeps hot face away from user
- Advanced refractory interior, used in combination with energy efficient low thermal mass insulation
- Programmable 3216P1 controller
- Over-temperature protection
- Digital RS232 communications on the following models: HTF 17/5, HTF 17/10, HTF 18/4 & HTF 18/8
- Fan cooling for low external case temperature
- The RHF 17/25 & HTF 18/15 both have electric door actuation



HTF 18/27 & HTF 17/5

Options (specify these at time of order)

- A range of sophisticated digital controllers, multi-segment programmers and data loggers is available. These can be fitted with RS232, RS485 or Ethernet communications (see pages 88-91)
- RS232 & RS485 communications (RHF 17/25, HTF 18/15 & HTF 18/27)

Technical data

Model	Max temp (°C)	Heat-up time (mins)	Dimensions: Internal H x W x D (mm)	Dimensions: External H x W x D (mm) H (door open)	Volume (litres)	Max power (W)	Digital RS232 Comms	Thermocouple type	Weight (kg)
HTF 17/5	1700	50	158 x 150 x 225	565 x 830 x 650 (850) (Bench-top)	5	4050	Standard	B	109
HTF 17/10	1700	44	232 x 200 x 225	565 x 830 x 650 (850) (Bench-top)	10	5920	Standard	B	133
RHF 17/25	1700	45	300 x 275 x 300	1800 x 1100 x 680 (2600) (Floor-standing)	25	9600	Option	B	400
HTF 18/4	1800	65	140 x 140 x 190	565 x 830 x 650 (850) (Bench-top)	4	4650	Standard	Pt20%Rh/Pt40%Rh	115
HTF 18/8	1800	56	210 x 190 x 190	565 x 830 x 650 (850) (Bench-top)	8	6200	Standard	Pt20%Rh/Pt40%Rh	128
HTF 18/15	1800	70	220 x 220 x 300	1580 x 690 x 800 (1735) (Floor-standing)	15	7900	Option	Pt20%Rh/Pt40%Rh	310
HTF 18/27	1800	55	300 x 300 x 300	1610 x 780 x 945 (1935) (Floor-standing)	27	8180	Option	Pt20%Rh/Pt40%Rh	509

i Please note:
 - Maximum continuous operating temperature is 100°C below maximum temperature
 - Heat up time is measured to 100°C below max, using an empty chamber

BLF bottom loading furnaces use an electrically operated elevator hearth which rises into the furnace chamber carrying the load.

This furnace provides the following advantages: easy loading of samples and uniform heating achieved by locating elements in all six side walls of the chamber.

Standard features

- 1700 °C & 1800 °C maximum operating temperature
- 3 to 21 litre capacities
- Ideal for: sintering high performance ceramics, melting glass under high temperature or working with modified atmospheres
- Rapid heating & cooling cycles can be achieved through raising & lowering the hearth
- Electrically operated elevator hearth protects operator from the chamber's radiant heat
- Excellent temperature uniformity as a result of the hexagonal chamber
- Over-temperature protection to protect load or furnace during unattended operation
- Programmable 3216P1 controller
- Molybdenum disilicide heating elements



BLF 17/3

Options (specify these at time of order)

- Compatible crucibles
- Modified hearth for the introduction of gases into an inverted crucible (not gas tight)
- Radiation shutter
- Hearth cage
- A range of sophisticated digital controllers, multi-segment programmers and data loggers is available. These can be fitted with RS232, RS485 or Ethernet communications (see pages 88-91)
- Customised options including: adaptation to introduce thermocouple or stirrer through the chamber roof and rotating hearth

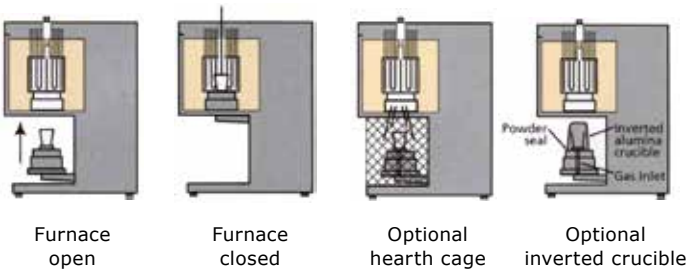

Technical data

Model	Max temp (°C)	Heat-up time (mins)	Dimensions: Internal H x Diameter (mm)	Dimensions: External H x W x D (mm)	Volume (litres)	Max power (W)	Thermocouple type	Weight (kg)
BLF 17/3	1700	80	190 x 150	975 x 750 x 530 (Bench-top)	3	4125	B	155
BLF 17/8	1700	80	250 x 200	1950 x 1360 x 800 (Floor-standing)	8	8130	B	424
BLF 17/21	1700	180	300 x 300	1850 x 1250 x 850 (Floor-standing)	21	12000	B	600
BLF 18/3	1800	110	190 x 150	975 x 750 x 530 (Bench-top)	3	4775	Pt20%Rh/Pt40%Rh	155
BLF 18/8	1800	110	250 x 200	1950 x 1360 x 800 (Floor-standing)	8	7010	Pt20%Rh/Pt40%Rh	424

i Please note:
 - Maximum continuous operating temperature is 100 °C below maximum temperature
 - Heat up time is measured to 100 °C below max, using an empty hearth

68 **STF – High Temperature Single Zone
Tube Furnaces**

The STF tube furnaces are available at 1500 °C & 1600 °C.

This range of tube furnaces does not include an integral work tube and one must be selected as an additional item. The work tube length is dependent on the application eg for use with modified atmosphere or vacuum. This information can be found on pages 92-93.

Standard features

- 1500 °C & 1600 °C maximum operating temperatures
- Accepts work tubes up to 60 or 90 mm outer diameter depending on model
- Heated lengths of 180, 450 or 610 mm
- Silicon carbide heating elements
- Horizontal configuration
- Carbolite 301 controller with single ramp to setpoint and process timer



STF 15/610 with L stand option

Options (specify these at time of order)

- Alternative mounting options are available (see page 39)
- Optionally configured for 2 phase or 3 phase electrical supply (depending on model)
- A range of additional work tubes is available in a variety of materials
- Insulation plugs & radiation shields to prevent heat loss & improve uniformity
- Modified atmosphere and vacuum end seal assemblies (see page 95)
- Over-temperature protection (recommended to protect valuable contents & for unattended operation)
- A range of sophisticated digital controllers, multi-segment programmers and data loggers is available. These can be fitted with RS232, RS485 or Ethernet communications (see pages 88-91)



STF 16/180

Technical data

Model	Max temp (°C)	Dimensions: Max outer diameter accessory tube (mm)	Dimensions: Heated length (mm)	Tube length for use in air (mm)	Tube length for use with modified atmosphere (mm)	Dimensions: External H x W x D (mm)	Dimensions: Furnace body length (mm)	Uniform length ±5°C (mm)	Max power (W)	Thermo-couple type	Weight (kg)	Power supply		
												Volt	Phase	Ampere per phase
STF 15/180	1500	60	180	600	900	625 x 600 x 375	600	80	1500	R	29	200-240	single phase	12
												110-120	single phase	24
STF 15/450	1500	90	450	900	1200	650 x 875 x 430	875	350	5500	R	34	200-240	single phase	39
												380-415	2 phase + N	19.5
												208	3 phase + N	25
STF 15/610	1500	90	610	1200	1500	650 x 1080 x 430	1080	400	6000	R	45	220-240	single phase	32
												200-208	single phase	44
												380-415	2 phase + N	19.5
												380-415	3 phase + N	19.5
												200-240	3 phase delta	34
STF 16/180	1600	60	180	600	900	625 x 600 x 375	600	80	2500	R	29	200-240	single phase	23
STF 16/450	1600	90	450	900	1200	650 x 875 x 430	875	350	6000	R	40	200-240	single phase	47
												380-415	2 phase + N	24
												380-415	3 phase + N	21
												200-240	3 phase delta	39
												380-415	3 phase no N	21
STF 16/610	1600	90	610	1200	1500	650 x 1080 x 430	1080	400	7000	R	50	200-240	single phase	50
												380-415	2 phase + N	25
												380	3 phase + N	25
												400-415	3 phase + N	27
												200-220	3 phase delta	43
												230-240	3 phase delta	46

i Please note:
 - Maximum continuous operating temperature is 100°C below maximum temperature
 - Uniform length measured with insulation plugs fitted

VST 17 – High Temperature Vertical Single Zone Split Tube Furnaces

The VST vertical split tube furnaces comprise a furnace body which is mounted on a vertical stand and split into two halves along its length.

The free standing vertical design is ideal for wrap around heating applications such as extension test rigs or vertical reaction tubes.

Usually requires, but does not include, an appropriate accessory work tube 32 mm, 66 mm or 90 mm maximum outer diameter.



VST 17/32/250

Standard features

- 1700°C maximum operating temperature
- Heated length of 250 mm
- Three models for tubes with outer diameters up to 32 mm, 32 to 66 mm and 66 to 90 mm
- Furnace splits into two halves to accommodate reactor vessels, large work pieces or samples fixed into a test rig
- Molybdenum disilicide elements
- Supplied with wide angle opening configuration complete with stand
- Control module with 2 m conduit
- Programmable 3216P1 controller
- Over-temperature protection

Options (specify these at time of order)

- A range of additional work tubes is available in a variety of materials
- Control module on longer 6 metre conduit
- Insulation plugs & radiation shields are strongly recommended for high temperature vertical tube furnaces to prevent heat loss & improve uniformity
- Modified atmosphere and vacuum end seal assemblies (see page 95)
- A range of sophisticated digital controllers, multi-segment programmers and data loggers is available. These can be fitted with RS232, RS485 or Ethernet communications (see pages 88-91)

Technical data

Model	Max temp (°C)	Dimensions: Max outer diameter accessory tube (mm)	Dimensions: Heated length (mm)	Tube length for use in air (mm)	Tube length for use with modified atmosphere (mm)	Dimensions: External Furnace (inc stand) H x W x D (mm)	Dimensions: Control module H x W x D (mm)	Max power (W)	Thermocouple type	Weight (kg)
VST 17/32/250	1700	32	250	750	1150	1160 x 600 x 705 (Bench-top)	630 x 600 x 490	4500	B	195
VST 17/66/250	1700	66	250	900	1150	1165 x 600 x 705 (Bench-top)	630 x 600 x 490	4500	B	205
VST 17/90/250	1700	90	250	1150	1150	1566 x 750 x 880 (Floor-standing)	630 x 600 x 490	4500	B	265

i Please note:
- Maximum continuous operating temperature is 100°C below maximum temperature

The CTF high temperature horizontal tube furnaces are available with heated lengths of 300 mm and 600 mm and maximum operating temperatures of 1700°C and 1800°C.



CTF 17/300

Standard features

- 1700°C & 1800°C maximum operating temperature
- Molybdenum disilicide elements
- Accepts work tubes with maximum outer diameter up to 90 mm
- 300 mm or 600 mm heated lengths
- Horizontal configuration only
- Programmable 3216P1 controller
- Over-temperature protection
- Tube guards and supports for extended tube length required for modified atmosphere

Options (specify these at time of order)

- A range of additional work tubes is available in a variety of materials
- Insulation plugs & radiation shields are strongly recommended for high temperature vertical tube furnaces to prevent heat loss & improve uniformity
- Modified atmosphere and vacuum end seal assemblies (see page 95)
- A range of sophisticated digital controllers, multi-segment programmers and data loggers is available. These can be fitted with RS232, RS485 or Ethernet communications (see pages 88-91).
- Alternative furnace sizes can be supplied upon request.

Technical data

Model	Max temp (°C)	Dimensions: Max outer diameter accessory tube (mm)	Dimensions: Heated length (mm)	Dimensions: External H x W x D (W including guards)	Tube length for use in air (mm)	Tube length for use with modified atmosphere (mm)	Uniform length ±5°C (mm)	Max power (W)	Holding power (W)	Thermocouple type	Weight (kg)
CTF 17/300	1700	90	300	880 x 720 x 630 (1360)	900	1200	200	4125	2500	B	126
CTF 17/600	1700	90	600	880 x 1020 x 630 (1660)	1200	1500	400	6875	3800	B	220
CTF 18/300	1800	90	300	945 x 720 x 630 (1360)	900	1200	200	6000	5200	Pt20%Rh/Pt40%Rh	130
CTF 18/600	1800	90	600	945 x 1020 x 630 (1660)	1200	1500	400	9300	5700	Pt20%Rh/Pt40%Rh	230

- i** Please note:
- Maximum continuous operating temperature is 100°C below maximum temperature
 - Holding power is measured at the continuous operating temperature
 - Uniform length measured with insulation plugs fitted

TZF – High Temperature 3-Zone Tube Furnaces

The TZF 3-zone high temperature tube furnaces are available at 1500 °C, 1600 °C, 1700 °C and 1800 °C. The heated length is divided into 3 zones.

An extended uniform zone in the mid-section of the work tube is achieved with the use of end zone controllers which track the centre zone temperature and compensate for the loss of heat from the tube ends.

Standard features

- 1500 °C and 1600 °C models have silicon carbide heating elements
- 1700 °C and 1800 °C models have molybdenum disilicide heating elements
- Accepts work tubes with maximum outer diameters up to 90 mm
- Heated lengths of 600 or 610 mm depending on the model
- End zone control is via back to back thermocouples (TZF 15)
- End zone control is via retransmission of set point (TZF 16, TZF 17 and TZF 18)
- Carbolite 301 PID controller with single ramp to setpoint & process timer (TZF 15 & TZF 16)
- Programmable 3216P1 controller (TZF 17 and TZF 18)
- Over-temperature protection (TZF 17 & TZF 18)



TZF 15/610

Options (specify these at time of order)

- A range of additional work tubes is available in a variety of materials
- Over-temperature protection (recommended to protect valuable contents & for unattended operation) (TZF 15 & TZF 16)
- Control module with 2 metre conduit to furnace
- Insulation plugs & radiation shields to prevent heat loss & improve uniformity
- Modified atmosphere and vacuum assemblies are available (see page 95)
- A range of sophisticated digital controllers, multi-segment programmers and data loggers is available. These can be fitted with RS232, RS485 or Ethernet communications (see pages 88-91)
- 'Retransmission of Setpoint' control configuration to facilitate programmed cooling (TZF 15)

Technical data

Model	Max temp (°C)	Heat-up time (mins)	Dimensions: Max outer diameter accessory tube (mm)	Dimensions: Heated length (mm)	Tube length for use in air (mm)	Tube length for use with modified atmosphere (mm)	Dimensions: External H x W x D (mm)	Max power (W)	Holding power (W)	Thermocouple type	Weight (kg)	Power supply		
												Volt	Phase	Ampere per phase
TZF 15/610	1500	75	90	610	1200	1500	650 x 1080 x 430	8000	4000	R	70	200-240	single phase	60
												380-415	3 phase + N	22
												220-240	3 phase delta	38
TZF 16/610	1600	-	90	610	1200	1500	650 x 1080 x 430	9150	4500	R	74	220-240	single phase	62
												380-415	3 phase + N	25
												220-240	3 phase delta	40
TZF 17/600	1700	150	90	600	1200	1500	880 x 1020 x 630	6800	3800	B	280	220-240	single phase	46
												208	single phase	48
												380-415	3 phase + N	28
												220-240	3 phase delta	34
TZF 18/600	1800	150	90	600	1200	1500	945 x 1020 x 630	5700	-	Pt20%Rh/ Pt40%Rh	280	220-240	single phase	40
												380-415	3 phase + N	24
												220-240	3 phase delta	28
												208	3 phase delta	30

i Please note:
 - Maximum continuous operating temperature is 100 °C below maximum temperature
 - Uniform length measured with insulation plugs fitted.

The HVTT high vacuum tube furnaces at 1500°C are available with two work tube diameters.

These units are often the starting point for additional customisation such as automated control of gate valves, gas purge, back-fill systems and co-ordinated control of roughing pump with the turbo-molecular high vacuum pump.

A lower temperature range at 1200°C is also available – please see page 57.



HVTT 15/50/450

Standard features

- 1500°C maximum operating temperature
- Capable of 10⁻⁵ mbar vacuum in a clean empty work tube
- Complete with work tube with inner diameters of either 50 or 75 mm
- Heated length of 450 mm
- Vacuum provided by oil-free scroll pump & turbo-molecular pump
- Cooling water failure alarm
- Manually operated roughing / backing valve
- Pirani gauge low vacuum monitor
- Penning gauge high vacuum monitor
- Work tube connects to the vacuum system via stainless steel connection
- Access to the work tube is via a removable stainless steel vacuum flange
- Radiation shields at both ends of the work tube maintain uniformity without reducing pump speeds
- All controls are mounted within the base unit

Options (specify these at time of order)

- Over-temperature protection (recommended to protect valuable contents & for unattended operation)
- A range of sophisticated digital controllers, multi-segment programmers and data loggers is available. These can be fitted with RS232, RS485 or Ethernet communications
- Custom built models including a variety of gas backfill systems, automatic & semi-automatic vacuum systems and 3-zone control for improved uniformity is available

Technical data

Model	Max temp (°C)	Dimensions: Work tube inner diameter (mm)	Dimensions: Heated length (mm)	Dimensions: External H x W x D (mm)	Max power (W)	Holding power (W)	Thermocouple type	Power supply		
								Volt	Phase	Ampere per phase
HVTT 15/50/450	1500	50	450	1565 x 1700 x 600	5500	4800	R	220-240 380-415	single phase 2 phase + N	45 26
HVTT 15/75/450	1500	75	450	1565 x 1700 x 600	5500	4800	R	220-240 380-415	single phase 2 phase + N	45 26

i Please note:
 - Maximum continuous operating temperature is 100°C below maximum temperature
 - Holding power is measured at the continuous operating temperature

The CDF Carbolite dental furnace is designed to provide easy sintering of zirconia (yttrium stabilised zirconium oxide) dental crowns and frameworks.

The furnace is equipped with a flexible 8 segment 3216P1 programmer and a heating system that only requires a conventional single phase (240V 13A) mains supply. Also included are a sintering tray and support beads.



CDF 15/1B

Standard features

- Optimised for operation from a standard 13A single phase mains supply
- Uniform heating from non-contaminating silicon carbide elements
- Highly uniform, accurately heated working zone
- Complete with sintering tray & 200 g of zirconium support beads 2 mm Ø
- 1 litre capacity chamber
- Ideal for small crowns & frameworks

Options (specify these at time of order)

- Over-temperature protection (recommended to protect valuable contents & for unattended operation)
- A range of sophisticated digital controllers, multi-segment programmers and data loggers is available. These can be fitted with RS232, RS485 or Ethernet communications (see pages 88-91)
- Spare sinter trays
- Spare sinter support beads

Technical data

Model	Max temp (°C)	Heat-up time (mins)	Dimensions: Internal H x W x D (mm)	Dimensions: External H x W x D (mm)	Volume (litres)	Max power (W)	Holding power (W)	Weight (kg)
CDF 15/1B	1530	126	80 x 90x 150	655 x 382 x 535	1	2000	1145	42



SCF 4

The SCF range of top loading crucible furnaces is available in 3 sizes with a maximum operating temperature of 1400 °C. They are specifically designed for the smelting of precious metals.

The furnaces are robustly constructed from heavy gauge hollow steel section and zinc coated sheet steel panels. Silicon carbide heating elements surround the chamber sides and are protected by silicon carbide tiles. The hearth is constructed from refractory bricks and silicon carbide tiles. The SCF 1 has a single chamber, all other models have twin chambers with separate lids.

Options (specify these at time of order)

- A range of sophisticated digital controllers, multi-segment programmers and data loggers is available. These can be fitted with RS232, RS485 or Ethernet communications (see pages 88-91)

Standard features

- Specifically designed for the smelting of precious metals
- The horizontal, parallel opening lids open with the hot face away from the user
- Each lid is vented by a 50 mm diameter chimney
- Silicon carbide heating elements protected by silicon carbide tiles
- The hearths of the SCF 4 and SCF 8 models include cast alumina supports to securely hold the appropriate number of crucibles
- The hearths of the SCF 24 and SCF 48 models are the same size but without crucible supports
- A 24 hour, 7 day timer

Technical data

Model	Max temp (°C)	Max continuous operating temp (°C)	Dimensions excluding handles: External H x W x D (mm)	Dimensions: Each chamber H x W x D (mm)	Dimensions: Control module H x W x D (mm)	Charge capacity	Thermocouple type	Max power (W)
SCF 1	1400	1350	850 x 905 x 905	440 x 285 x 285	630 x 600 x 490	-	R	15000
SCF 4	1400	1350	990 x 1230 x 1040	200 x 245 x 500	630 x 600 x 490	4 crucibles 120 x 180 (OD x H mm)	R	15000
SCF 8	1400	1350	1025 x 1350 x 1300	200 x 245 x 760	630 x 600 x 490	8 crucibles 120 x 180 (OD x H mm)	R	21000
SCF 24	1400	1350	990 x 1230 x 1040	200 x 245 x 500	630 x 600 x 490	24 crucibles 79 x 97 (OD x H mm)	R	15000
SCF 48	1400	1350	1025 x 1350 x 1300	200 x 245 x 760	630 x 600 x 490	48 crucibles 79 x 97 (OD x H mm)	R	21000

The following pages show examples of furnaces up to 3000°C. Also included is information on the range of coal, coke and iron ore testing furnaces and ovens, in addition to custom built furnaces and ovens for specialist applications. This section is completed by an overview of product configurations.

WSP

Working Output

SP

0.0%

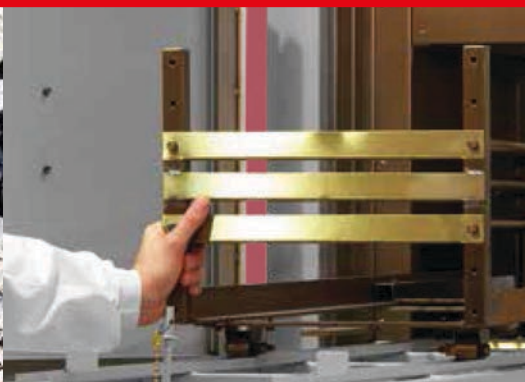

Working Output	0.0%
SP1	290°C
Mode	Manual
Man Op	-14.90
11:05:30 01/04/1	

Man Op -14.90



	Page
Furnaces up to 3000 °C (Gero Products)	78
Coal and Coke Test Equipment	80
Custom Built Equipment	84
Product Configurations	
Temperature Control Options	88
Work Tube Selection Guide	92
Work Tube Accessories	94
Modified Atmosphere Options	95
Power Supply Information	96



GERO
 A CARBOLITE COMPANY 30-3000°C

As part of Carbolite, Gero Hochtemperaturöfen GmbH & Co. KG is a manufacturer of industrial furnaces based in Neuhausen near Stuttgart in southern Germany with more than 30 years of professional heat treatment experience – from standard products to customer specific system solutions. Its key capabilities extend the Carbolite portfolio with furnaces for high temperature applications up to 3000 °C under vacuum, inert gas or reactive atmosphere (eg hydrogen). The main areas of application are universities and industrial research, as well as products for small to medium production. Some examples of the product range are shown below. For more information, separate product brochures are available.

Laboratory Furnaces – LHT

- Series LHTG / LHTM / LHTW furnaces (using Graphite, Molybdenum or Tungsten as heating and insulation material) are typical laboratory furnaces designed for all types of heat treatment processes (eg in material science). They are used for high vacuum applications up to 1×10^{-6} mbar and very pure atmospheres of hydrogen
- The versions made of graphite are standard rated for 2200 °C, but can also be supplied for temperatures up to max. 3000 °C
- The furnaces are available with manual operation as standard
- Fully automatic control with SIEMENS PLC and WINCC visualisation is available as an option



LHTG 100

Advantages

- Particularly robust and durable design of heating system and insulation (LHTG)
- Pressure control between 10 – 1000 mbar for each process gas
- Smooth controlled evacuation appropriate for powders
- Charging racks for the highest temperatures made of metal
- TÜV-proven safety management for flammable and poison gases
- Full automatic operation also for highly complex processes
- Data recording for quality management

Chamber Furnaces – HTK

- The HTK range is available in three different versions (Molybdenum, Tungsten or Graphite) and in up to six different sizes. The smallest designs with 8 litre and 25 litre capacity are usually employed by laboratories for research and development. The 80 litre to 600 litre capacity versions are predominantly used as plant for pilot manufacture and for production
- Applications include pyrolysis, siliconizing and graphiting, metal powder injection moulding, tempering of sapphires, sintering of pellets in the nuclear industry, manufacture of radar tubes, metallisation of ceramic components and high vacuum brazing

HTK 400



EBO for catalytic debinding



GLO for thermal debinding

Metal Injection Moulding (MIM) & Debinding and Sintering Furnaces

- High volume production of complex metal parts is more and more often done using metal injection moulding. During this process a metal/binder mixture is filled into precisely pre shaped forms. Removed from these forms the parts then need to be debinded and finally sintered to obtain the desired mechanical properties
- Gero offers optimized products for debinding and sintering
- Series HTK (see above) is also suitable for the debinding and sintering process



PDS for partial pressure sintering

The range of coal and coke tests carried out in a furnace or oven has grown over many years, and Carbolite has responded to the requirements of each new standard by designing a furnace to suit the specific requirements of each test method. As a result, Carbolite products have become established as the standard equipment used in many coal laboratories, inspection companies, power plants and steelworks throughout the world. The range includes international coal and coke testing and iron ore evaluation test methods, including ISO, ASTM, EN, BS, and DIN. Some examples follow, but this is not a complete list. For further information please consult our separate coal and coke brochure or enquire at info@carbolite.com.

Coal ashing furnaces

The AAF series of ashing furnaces suit many coal (and other materials) ashing tests, including ISO 334 & ISO 1171:2010 Solid mineral fuels – determination of ash, ASTM D2361 & D3174-04(2010) Standard Test Method for Ash in the Analysis Sample of Coal and Coke from Coal, BS 1016 part 4.

- Maximum temperature 1100 °C
- Continuous preheated airflow, to ensure temperature uniformity of better than $\pm 10^{\circ}\text{C}$ throughout the uniform volume
- Constant airflow held close over the samples to promote burning (AAF 11/3 and AAF 11/7 models have 4-5 air changes per minute)
- Traditional muffle heated chamber gives good resistance to abrasion and vapour attack (AAF 11/3 & AAF 11/7)
- A range of sophisticated controllers and programmers is available, along with data logging equipment



Volatile matter furnaces

The VMF models meet the different test methods of ISO 562 and ASTM D3175; both tests relate to testing the quality and contamination level in coal. By placing the sample in a crucible with a close fitting lid the volatile matter is given off before oxidation

ISO 562:2010 hard coal and coke – determination of volatile matter

- Fast heating open spiral elements supported in low thermal mass insulation to ensure the rapid heating required by the standard
- Calibration ports are provided to allow insertion of unsheathed probe thermocouples from the back of the chamber
- Suits crucible measuring 21 mm id / 25 mm od x 38 mm high and close fitting lid
- 4 or 9 crucible rack available (additional option)
- A range of sophisticated controllers and programmers is available, including over-temperature protection, along with data logging equipment

ASTM D3175-11 standard test method for volatile matter in the analysis sample of coal and coke

- Top loading 50 mm diameter design x 100 mm deep, with hinged lid
- Crucible holder included as standard
- Crucible 25.5 mm inside top diameter / 17 mm diameter inside bottom. Overall height 34 mm; separate lid to fit (available as an option)
- A range of sophisticated controllers and programmers is available, including over-temperature protection, along with data logging equipment



Minimum free space oven

The MFS/1 model operates at up to 200 °C, with a regulated flow of moisture free bottled nitrogen gas which carries the moisture released by the coal at 105 °C

- BS 1016: part 104, ISO 11722
- Nitrogen flow of approximately 15 oven volume changes per hour
- Post-test storage desiccator available (additional option)
- A range of sophisticated controllers and programmers is available, including over-temperature protection, along with data logging equipment



Swelling number furnace

The SNF model operates at up to 900 °C, and indicates to what extent a coal sample will swell during coking

- BS 1016: part 107, ISO 501, ASTM D720
- Top loading 55 mm diameter design x 85 mm deep, with hinged lid
- Wire crucible holder included as standard
- Suits 1 x 17 ml crucible; 26 mm H x 41 mm ø at top and 14 mm ø at base and close fitting lid (additional option)
- A range of sophisticated controllers and programmers is available, including over-temperature protection, along with data logging equipment



Coal ash fusibility furnaces (CAF)

The CAF digital model meets the following standards:

- BS ISO 540:2008. Hard coal and coke. Determination of ash fusibility
- ASTM D1857/D1857M – 04 (2010) - Standard Test Method for Fusibility of Coal and Coke Ash
- PD CEN/TR 15404:2010 Solid recovered fuels – Methods for the determination of ash melting behaviour by using characteristic temperatures
- DD CEN/TS 15370-1 2006 Solid biofuels – Methods for the determination of ash melting behaviour – Part 1

The CAF digital model has the following features:

- Automatically records images of the melting test pieces, up to a maximum of 1 image/°C change
- Software to determine quickly the melting points of the test pieces
- Images recorded to PC with bespoke software (both supplied)
- Choice of gases to meet relevant standards (must be specified at the time of order)
- Adjustable flow meters and gas pressure monitoring system with nitrogen safety purge
- Up to 12 samples can be analysed simultaneously
- Model suitable for analysis of biomass and solid recovered fuels (specify at the time of order)
- Test piece moulds, stands and tiles supplied



Coke reactivity

ISO 18894 Method for Measuring Coke Reactivity Index (CRI) and Coke Strength after Reaction (CSR).

A dry coke sample of designated size and origin is reacted with CO₂ gas in a retort at a specified elevated temperature for a specified length of time. Two indices, coke reactivity index (CRI) and coke strength after reduction (CSR) are determined using the reacted coke residue. The weight retained after reduction determines the CRI. The weight retained after sieving the tumbled reacted coke in a designated number of revolutions over a designated turning rate determines the CSR.

- Maximum operating temperature 1100 °C
- Three zone heating over 700 mm
- The test profile is controlled by the main temperature controller, which also controls both temperature and gas flow
- Dual loop cascade control
- Supplied with Inconel retort
- Over-temperature protection
- Flame failure gas safety system



Dynamic test for low temperature reduction – disintegration – ISO 13930 (previously known as the Linder test)

Iron ore pellets are placed in a rotating tube and subjected to “tumbling during reduction”. The samples are then subjected to a sieve analysis to determine the degree of disintegration.

- Maximum temperature 600°C
- Three heated zones over 715mm
- Dual loop cascade control
- Supplied with retort
- Over-temperature protection
- Flame failure gas safety system
- Paperless data logging



Iron ore reducibility – ISO 4695 – 4696-1 Combined Test Unit

Reducibility may be defined as a measure of the ease with which oxygen combined with iron can be removed from natural or processed iron ores by a reducing gas, which is expressed as the rate of reduction at an atomic ratio O/Fe = 0.9, relative to the iron (III) state. Test consists of isothermal reduction of a test portion at a specified size range in a fixed bed at a temperature of 950 °C using a reducing gas consisting of CO and N₂

- Maximum temperature: 1100 °C
- Three heated zones over 700 mm
- Balance to determine the loss in mass of the reduced sample with a resolution of 0.1 g connected to the retort during the entire process cycle.
- Dual loop cascade control
- Supplied with retort
- Over temperature protection
- Flame failure gas safety system



Coke test oven – Nominal charge weight: 7 kg

- Designed for testing granulated and graded coals for coking under accurately controlled conditions
- Does not measure pressure generated during the coking
- Charge hopper, loading/unloading trolley, quench cart & discharge ram and electrical afterburner (additional options)



Moving wall coke test oven – 227 kg

Moving wall test oven was developed in close conjunction with UK Coal Research Establishment. The oven is designed for testing suitably granulated and graded coals for coking under accurately controlled conditions. The oven chamber is designed to allow the pressure generated during the coking to be exerted against a fixed wall on one side of the chamber and a moving wall on the other. The pressure is measured by a load transducer actuated by the moving wall.

- Maximum temperature: 1300 °C
- Nominal charge weight: 227 kg (500 lb)
- Optional afterburner
- Multi-function control, recording and visualisation in a single process with colour touchscreen display
- Large internal data archive, with choice of secure logging or CSV



This section demonstrates Carbolite's expertise in designing and building equipment to meet specific customer requirements. Some examples are given on the following pages. For further information please enquire at info@carbolite.com.

Special high temperature modified atmosphere oven for use with inert atmosphere

- Maximum operating temperature: 700 °C
- Working temperature: 100 – 700 °C
- 95 litre capacity
- Temperature uniformity: better than $\pm 5^{\circ}\text{C}$ in an empty chamber
- Controller accuracy: better than $\pm 1^{\circ}\text{C}$
- Air or gas is circulated around the chamber by a centrifugal fan mounted in the back of the oven
- Gas sealing of the chamber is achieved by seam welding. An exhaust pipe and relief valve take away the gases
- Fitted with an oxygen monitoring system, with a working level of approximately 50 ppm



Custom designed tube furnace solution for research institute

- 2 x 3-zone tube furnaces mounted on rails which allows the furnaces to be linked together to create a temperature gradient, or used independently
- 1 furnace has a heated length of 600 mm and the second one a heated length of 400 mm
- Used with quartz tube of 45 mm diameter

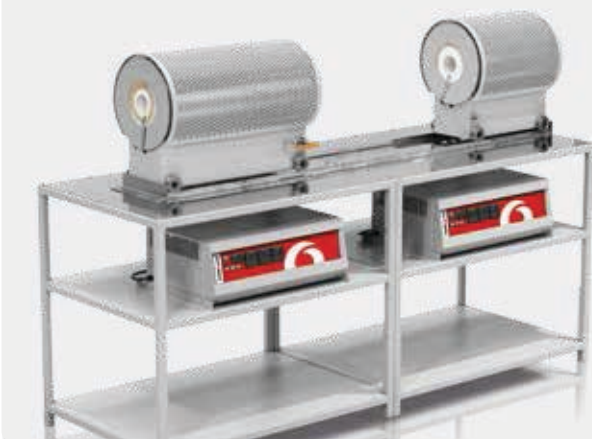

Vertical thermal cycling rig for testing of ceramic coatings for turbine blades

- Maximum operating temperature: 1600 °C
- Heated length: 1 x single zone of 300 mm
- Maximum sample weight: 8 kg
- Automatic process lifts the sample into the heated zone; when the sample thermocouple reaches 1400 °C, a time of 2 hours is counted down and the sample then passes into the quench zone for cooling by fans. When the sample thermocouple reaches 100 °C, the cycle is repeated



Rotating, tilting 3-zone horizontal tube furnace for continuous sintering of material for catalysts

- Maximum operating temperature: 1300°C
- Heated length of 1400 mm over 3-zones
- Temperature uniformity: $\pm 5^\circ\text{C}$ over 3-zones
- Special industrial grade spiral wire elements in ceramic fibre half cylinders
- Loss in weight feeder system
- Operates in oxygen levels of <100 ppm
- HMI control panel



Front loading gas tight chamber furnace for sintering of graphite ceramic powders

- Maximum operating temperature: 1100°C
- 601 Inconel retort
- Atmosphere: 97% nitrogen / 3% hydrogen
- 3 controlled zones running along the length of the furnace
- Hinged furnace roof is fitted with an electric lift mechanism which opens to aid fast cooling

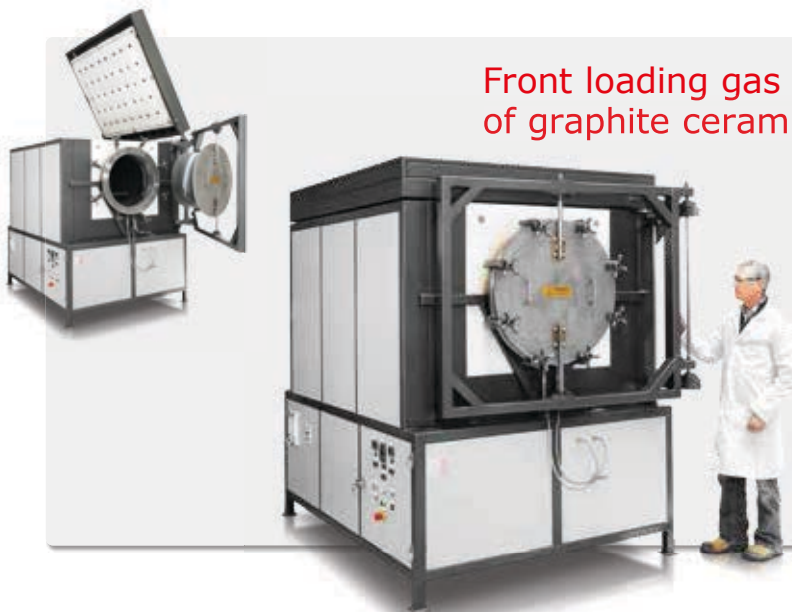

General purpose oven, model GP 450A, suitable for batch production in a light industrial environment

- Meets the requirements of AMS 2750E for Class 2 and type D instrumentation for use in a Nadcap certified facility
- Operating temperature: ambient $+10^\circ\text{C}$ to 300°C
- Temperature uniformity: better than $\pm 5^\circ\text{C}$
- An output from the control thermocouple is provided for connection to the customer's own data logging equipment



Tilting crucible furnace for melting aluminium

- Designed to melt 10 to 15 kg of aluminium
- Maximum operating temperature: 1100 °C
- Temperature uniformity: ± 5 °C
- Fitted with an A50 8-litre crucible with an extension spout for easy pouring
- Variable speed hydraulic power pack ensures smooth operation



Bottom loading crucible furnace for glass melting

- Maximum operating temperature: 1700 °C
- Capacity: 3.4 litres
- Heat up rate: 20 °C / minute
- Temperature uniformity: ± 2 °C
- Bottom loading allows heavy and delicate loads to be easily handled
- 600 mm forward / back movement of hearth and crucible for ease of molten glass collection

Special design horizontal split tube furnaces with longer heated length and larger diameter tubes. Suitable for applications in fuel cell or solar cell research.

- Maximum operating temperature: 1200 °C
- Heated lengths: 600 and 1200 mm
- Tube diameter: 200 and 300 mm
- Excellent temperature uniformity
- Available as single or 3-zone models
- Vertical models also available

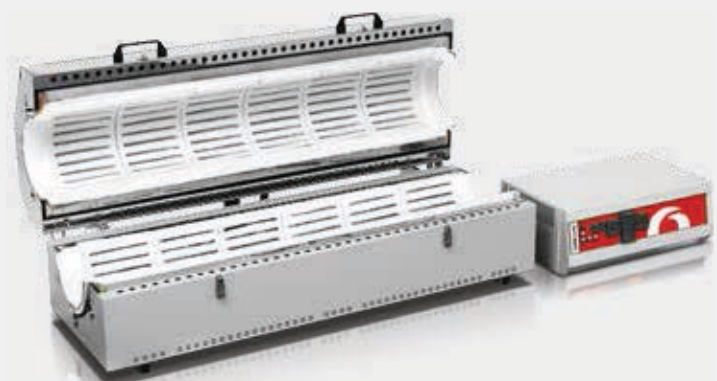

High temperature oven with retractable shelf for speed of loading/unloading

- Maximum operating temperature: 400 °C
- Working temperature: 50 to 400 °C
- Temperature uniformity: better than $\pm 5^{\circ}\text{C}$
- Forced air circulation



Three zone tube furnace for automated calibration of thermocouples

- Maximum operating temperature: 1200 °C
- 3 heated zones
- Temperature uniformity: $\pm 5^{\circ}\text{C}$
- The 6 test thermocouples are mounted on a support which is driven by an actuator and controlled by a timer

Integrated 3-oven system for drying applications

- 3 separately controlled ovens mounted within one framework
- Two small chambers on the left and a larger one on the right
- Operating temperature: 50 to 300 °C
- Meets AMS2750E for Class 2 and type D instrumentation
- Temperature uniformity: better than $\pm 5^{\circ}\text{C}$ over the full working temperature
- Each chamber is fitted with both SAT and TUS ports
- 6-channel graphic data recorder



88 Temperature Control Options

301 Standard controller

The 301 PID controller has a large display mounted behind a smooth wipe-clean membrane and offers a single ramp to set point. It includes a 99 hour process timer which can be programmed for a timed delay at the start of the process or used as a countdown timer.



The 301 provides precise PID (Proportional Integral Derivative) control meaning that ramp rates and set points are very closely followed.

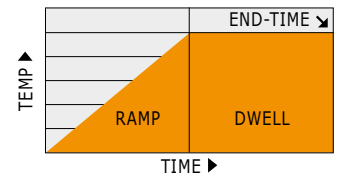

Options

301 Over-temperature control

This option offers a variable set point to protect either the chamber or the load. Selection of this option provides an additional independent thermocouple and protection circuit which is fully integrated into the 301 controller. Whilst all Carbolite products are designed to fail safe in the event of a controller malfunction, over-temperature protection is strongly recommended for unattended operation or where valuable loads are to be processed.



Programmable controllers

3216P1 & 3216P5

These controllers offer programmable control using up to 8 segment pairs, each segment comprising a ramp followed by a dwell; the dwell may be set to zero time. The 3216P5 can also store and retrieve up to 5 separate programs.

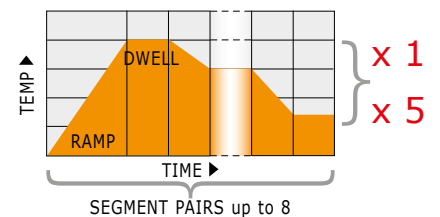

3508P1, 3508P10 & 3508P25

These controllers offer programmable control in which 20 segments may be set as ramp, step or dwell and may also be configured to control relays or logic outputs. The 3508 series provide a comprehensive information display. If precise temperature control is required over a wide range of temperatures, the 3508 series allows the use of multiple PID terms (gain scheduling). This feature is not enabled as standard, but can be activated on request. The 3508P10 and 3508P25 can also store and retrieve 10 and 25 programs respectively.

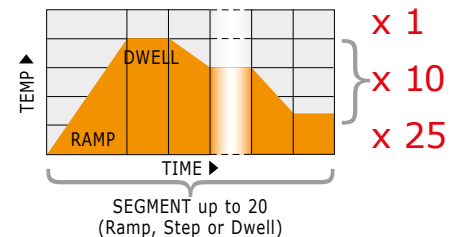

Options

Over-temperature control



This has a variable set point to protect either the furnace, oven or the load. If the main controller is from the 3216 or 3508 series this is provided by the addition of an independent 2132 controller. Whilst all Carbolite products are designed to fail safe in the event of a controller malfunction, over-temperature protection is strongly recommended for unattended operation or where valuable loads are to be processed.



Eurotherm nanodac™

Recorder & PID controller

In this configuration the nanodac™ combines precision PID temperature control, with a fully functional data logger. The full colour display can be changed to display text in English, French, German, Italian or Spanish.

Data is continuously logged into either CSV (comma separated variable) or securely to UHH (Eurotherm Hydra History) files. Data can be archived onto a USB flash drive or via Ethernet to a networked server. Up to 4 channels can be recorded, with up to 14 virtual channels that can be set to record trends, alarms, communications or mathematical functions such as totals or averages.

Logged files can be opened and displayed on a PC, in chart form, using Eurotherm Review Lite software.

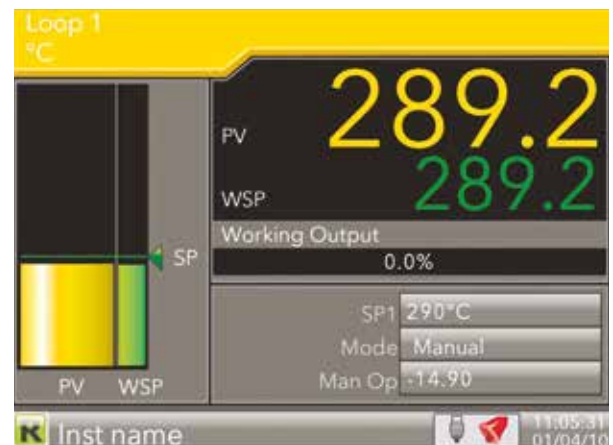

Recorder & PID programmable controller

This controller offers programmable control in which 25 segments may be set as a ramp, step or dwell and may also be configured to control relay or logic outputs. It stores and retrieves 100 programs.

Additional programs can be saved to, and retrieved from, a networked server via a USB flash drive or Ethernet. The action of up to 3 relays, or logic outputs, can be linked to a program segment; this can be used to switch on external devices such as gas solenoid valves and audible alarms. Note that some configurations may require additional components.

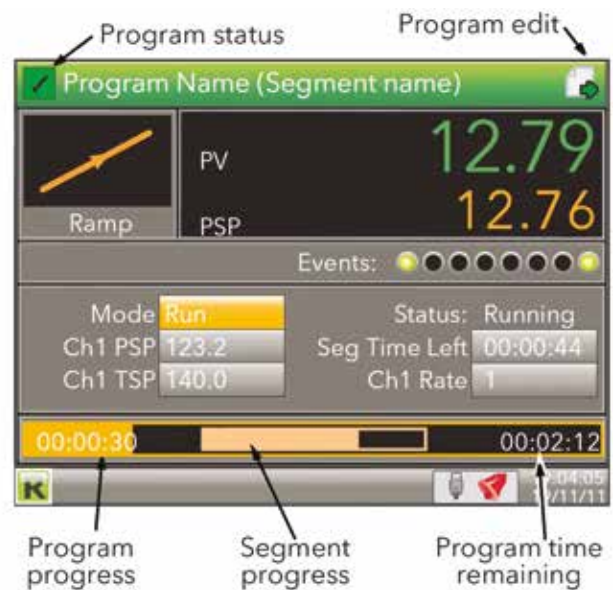
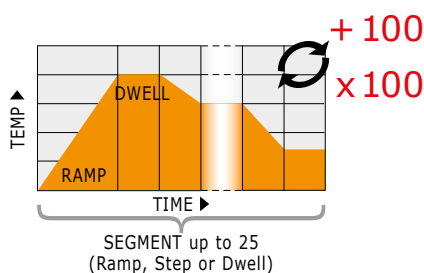

In this configuration the nanodac™ can hold up to 100 programs

RS232, RS485 and Ethernet communications

- RS232 allows a single controller to communicate with a single computer
- RS485 allows multiple controllers to communicate with a single computer
- Both require, but do not include, suitable PC based software (eg iTools) and connection cables
- 301 controller – RS232 is only available when ordered with over-temperature option (RS485 is not available with the 301 controller)
- 3216 and 3508 series controllers both have the option to add RS232 or RS485 communications
- Ethernet communication is supplied as standard with the nanodac™ controller and is optional in the 3508 series

Cascade control

This feature offers the benefit of precise temperature control of the load. A standard controller operates by sensing the temperature close to the elements. With cascade control the controller's operation includes a second control thermocouple, which is used to sense the temperature of the load. It is essential that the controller is a dual loop 3508 or dual loop nanodac™.

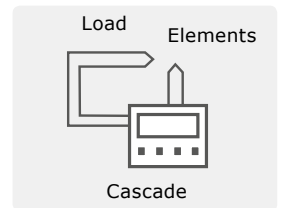

Three zone control

This has the function in 3-zone tube furnaces of extending the length of the uniform heated zone.

Back-to-back control

This configuration is supplied as standard for all Carbolite 3-zone tube furnaces.

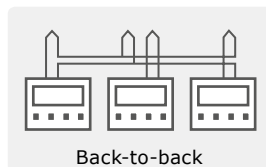

Retransmission of set point

This configuration is primarily available for 3-zone tube furnaces where programmed cooling is required.

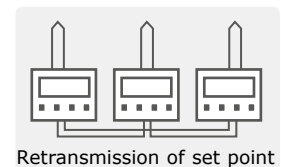

Independent control

This configuration comprises three independent controllers, each with an independent thermocouple in its respective zone. This option is not designed to create a temperature gradient.

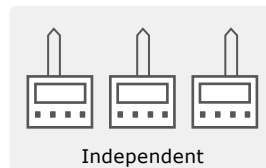

Three zone cascade control

As in single zone furnaces, cascade control allows faster heating of the furnace load and more precise control of the load temperature. A 3508 or nanodac™ controller is required, the end zones are controlled using (non-programmable) 3216 CC controllers.

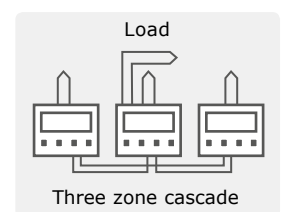

Chart recorders & DAQs (Data acquisition devices)

This is just a small selection of the options that are available for recording data from Carbolite products. If you require advice, please contact Carbolite for further information. **NOTE:** Please confirm with Carbolite whether the chart recorder required can be fitted within the standard product case; in some instances it may require mounting in a separate case.

4102 series 100 mm wide compact strip chart recorder

The 4102 series are compact and economical 100 mm strip chart recorders, providing recording for up to 4 (continuous pen) or 6 (multi-point) process variables.



4103 series 100 mm wide strip chart recorder

The 4103 is a high specification, 100 mm strip chart recorder, providing continuous recording for up to 6 process variables. Information such as channel descriptor, alarm set point and scale information can be viewed on a high resolution display.



Model	Channels (pens)	User programmable	Accuracy to paper (%)	Speed (mm/hr)	Annotation
4102 C	1	no	0.25	10, 30, 60, 120 or 5, 20, 60, 120 or 20, 30, 60, 120 or 30, 60, 120, 300	Extra option
4102 C	2	no			Extra option
4102 M	6	no			Standard
4103 C	1	yes		Software selectable	Standard
4103 C	2	yes			Standard
4103 M	6	yes			Standard

Eurotherm nanodac™ DAQ recorder only

In this configuration the nanodac can be used in combination with a conventional controller as a paperless chart recorder. Data is continuously logged into either CSV (comma separated variable) or secure UHH (Eurotherm Hydra History) files. Data can be archived onto a USB flash drive or via Ethernet to a networked server. Up to 4 channels can be recorded, with up to 14 virtual channels that can be set to record trends, alarms, communications, or mathematical functions such as totals or averages. Logged files can be opened and displayed on a PC, in chart form, using Eurotherm Review Lite software.

6100 & 6180 series digital data acquisition, recording & display

A series of digital data acquisition recorders which can function as stand-alone paperless recorders or with more advanced models can be integrated into computer networks. All have the capability to archive data via USB flash memory devices or onto a networked server using Ethernet FTP or Modbus TCP (although the 6100E is Slave configuration only). 6100 series data recorders have a 5.25" TFT touch screen interface whilst the 6180 series data recorders have a 12.1" TFT touch screen interface.



The 6100 XIO and 6180 XIO data recorders record digital data and so must be used with controllers that are equipped with digital communications. This overcomes potential issues from the attenuation of analogue signals over distance. The 6180 AeroDAQ is a recorder configuration that has been optimised for AMS 2750E (Nadcap) applications and includes thermocouple monitoring.



Always confirm with Carbolite that your preferred data recorder can be fitted within the standard furnace case, alternatively a stand-alone cabinet may be required.

The following software options are available for use with the 6100 A, 6100 XIO and 6180 series data recorders for the 6100 series (these options are not compatible with the 6100 E model):

- Batching
- Grouping
- Screen Builder
- Bridge Software

Model	Function	Channels	Display screen	On-board memory for history (Mb)	USB ports	Serial ports
nanodac	PID control & record	4	89 mm TFT & software allocated keys	50	1	0
6100E	record analogue input	3 or 6	100 mm VGA touchscreen	8	1	0
6100A	record analogue input	6, 12 or 18	100 mm VGA touchscreen	32 or 96	up to 3	up to 2
6180A	record analogue input	6, 12, 18, 24, 30, 36, 42 or 48	180 mm XGA touchscreen	96	up to 3	up to 2
6100XIO	record digital comms input	128 virtual channels	100 mm VGA touchscreen	96	1	2
6180XIO	record digital comms input	128 virtual channels	180 mm XGA touchscreen	96	1	2
6180 AeroDAQ	record analogue input	6, 12, 18, 24, 30, 36, 42 or 48	180 mm XGA touchscreen	96	3	2

iTools software

A versatile suite of software that allows Carbolite products that have been fitted with appropriate digital communications hardware to be set-up, recorded and monitored from a PC. The supplied licence is for a single PC to communicate with one furnace using RS232 or with many furnaces using RS485. **NOTE:** The 301 controller is not compatible with RS485 communications.

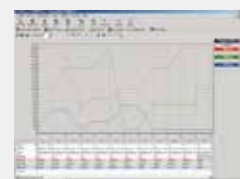

Calibration certificates

The following calibration options can be supplied, each of which is available with a certificate from a UKAS accredited laboratory, which is traceable to a UK national standard

- UKAS traceable certificate for the thermocouple only, calibrated at 3 temperature points, specified by the customer
- UKAS traceable certificate for the temperature controller only, calibrated at 3 temperature points at temperatures specified by Carbolite

- UKAS traceable certificate at 3 temperature points for both thermocouple & temperature controller
- For advice and specifications to comply with AMS 2750E (Nadcap) for heat treatment applications, please contact Carbolite

The material, length and diameter of the work tube required for use with each furnace differs. The appropriate material as well as correctly sized work tube for each furnace can be selected from the tables below. Work tube length depend on whether the furnace will be used to work in air or with modified atmosphere/vacuum.

Tube material	Physical & chemical properties			Maximum temperatures in air (°C)	
	Porous / Impervious	Resistance to thermal shock is partly dependent upon specific tube dimensions	Chemical resistance	Horizontal	Vertical
Sillimanite (AL₂SiO₅)	Porous	Good	Good chemical resistance but porous	1500	1600
IAP (Impervious aluminous porcelain)	Impervious	Very good	Good chemical resistance against gases, with the exception of fluorine	1400	1500
Mullite (3Al₂O₃·2SiO₂)	Impervious	Very good	Resistant to flux sulphurous or carbonaceous atmospheres	1500	1550
RCA (Recrystallised alumina)	Impervious	Good	Highly resistant to chemical attack, with the exception of fluorine	1800	1900
Quartz	Impervious	Excellent	Generally good but reactive with sodium & at upper temperature limit with metals, carbonates & halides	1100	1100
APM (Advanced powder metallurgy – FeCrAl) Unsuitable for use in wire wound tube furnaces due to high electrical conductivity	Impervious	Excellent	Resistant to oxidation, carburization & sulphidation	1300 (Long or unsupported tubes will bend at this temperature)	1350

MTF – CTF – TZF

The furnaces are constructed *with* an integral ceramic tube onto which the heating element is wound. An inner “work tube” is an option to protect the integral work tube when heating in air and is essential when gas tight or vacuum tight seals are to be added. The inner “work tube” lengths are as follows:

Model	Inner work tube for use in air			Inner work tube for use with modified atmosphere or vacuum		
	Length (mm)	Inner diameter (mm)	Outer diameter (mm)	Length (mm)	Inner diameter (mm)	Outer diameter (mm)
MTF 12/38/250	300	25	32	600	25	32
MTF 12/38/400	450	25	32	750	25	32
MTF 12/38/850	900	25	32	1200	25	32
CTF 12/65/550	600	50	60	900	50	60
CTF 12/75/700	750	60	70	1050	60	70
CTF 12/100/900	950	80	95	1200	80	95
TZF 12/38/400	450	25	32	750	25	32
TZF 12/38/850	900	25	32	1200	25	32
TZF 12/65/550	600	50	60	900	50	60
TZF 12/75/700	750	60	70	1050	60	70
TZF 12/100/900	950	80	95	1200	80	95

EHA, EHC, EVA, EVC, EST & EZS – EVT & EVZ

E-range furnaces are constructed *without* an integral ceramic tube as the heating elements are vacuum formed into the insulation. An inner “work tube” must always be used whether heating in air or to allow gas tight or vacuum tight seals to be added. The inner “work tube” lengths are as follows:

Model	Inner work tube length for use in air (= heated length + 150 mm)		Inner work tube length for use with modified atmosphere or vacuum (= heated length + 300 mm)	
	Length (mm)	Max outer diameter (mm)	Length (mm)	Max outer diameter (mm)
EHA, EHC, EVA, EVC, EST & EZS				
E /150	300	60	450	60
E /300	450	60	600	60
E /450	600	60	750	60
E /600	750	60	900	60
Model	(= heated length + 300 mm)		(= heated length + 300 mm)	
EVT & EVZ				
E /150	450	60	450	60
E /300	600	60	600	60
E /450	750	60	750	60
E /600	900	60	900	60

GHA, GHC, GVA & GVC

G-range furnaces are constructed *without* an integral ceramic tube as the heating elements are vacuum formed into the insulation. An inner "work tube" must always be used whether heating in air or to allow gas tight or vacuum tight seals to be added. The inner "work tube" lengths are as follows:

Model	Inner work tube length for use in air (= heated length + 200 mm)		Inner work tube length for use with modified atmosphere or vacuum (= heated length + 600 mm)	
	Length (mm)	Max outer diameter (mm)	Length (mm)	Max outer diameter (mm)
GHA, GHC, GVA & GVC				
G /300	500	170	900	170
G /450	650	170	1050	170
G /600	800	170	1200	170
G /750	950	170	1350	170
G /900	1100	170	1500	170
G /1050	1250	170	1650	170
G /1200	1400	170	1800	170

HST & HZS – VST & TVS

Split tube furnaces are constructed *without* an integral ceramic tube as the heating elements are vacuum formed into the insulation. An inner "work tube" must always be supplied, to put the sample inside, whether heating in air or to allow gas tight or vacuum tight seals to be added. The inner "work tube" lengths are as follows:

Model	Inner work tube length for use in air (= heated length + 150 mm)*		Inner work tube length for use with modified atmosphere or vacuum (= heated length + 450 mm)	
	Length (mm)	Max outer diameter (mm)	Length (mm)	Max outer diameter (mm)
HST 12/200	350	110	650	110
HST 12/300	450	110	750	110
HST 12/400	550	110	850	110
HST 12/600	750	110	1050	110
HST 12/900	1050	110	1350	110
HZS 12/600	750	110	1050	110
HZS 12/900	1050	110	1350	110

Model	(= heated length + 350 mm)	(= heated length + 450 mm)
VST 12/200	550	650
VST 12/300	650	750
VST 12/400	750	850
VST 12/600	950	1050
VST 12/900	1250	1350
TVS 12/600	950	1050
TVS 12/900	1250	1350

STF & TZF – CTF & TZF – VST

The tube furnaces are constructed *without* an integral ceramic tube. An inner "work tube" must always be supplied, to put the sample inside, whether heating in air or to allow gas tight or vacuum tight seals to be added. The inner "work tube" lengths are as follows:

Model	Inner work tube length for use in air		Inner work tube length for use with modified atmosphere or vacuum	
	Length (mm)	Max outer diameter (mm)	Length (mm)	Max outer diameter (mm)
STF 15/180	600	60	900	60
STF 15/450	900	90	1200	90
STF 15/610	1200	90	1500	90
STF 16/180	600	60	900	60
STF 16/450	900	90	1200	90
STF 16/610	1200	90	1500	90
TZF 15/610	1200	90	1500	90
TZF 16/610	1200	90	1500	90

CTF 17/300	900	90	1200	90
CTF 17/600	1200	90	1500	90
CTF 18/300	900	90	1200	90
CTF 18/600	1200	90	1500	90
TZF 17/600	1200	90	1500	90
TZF 18/600	1200	90	1500	90

VST 17/32/250	750	32	1150	32
VST 17/66/250	900	66	1150	66
VST 17/90/250	1150	90	1150	90

i Please note:

*For HST and HZS models, fitted with 'L' stand, for use in air work tube length required is the same as VST models

To ensure the correct accessories are supplied, please specify the furnace model (horizontal or vertical use), work tube dimensions (inner diameter, outer diameter and length) and operating temperature.

Ceramic insulation plugs

Ceramic insulation plugs are designed to reduce heat loss from tube ends and improve temperature uniformity. They are particularly helpful for vertical tubes and tubes with diameters greater than 25 mm. Different insulation plugs are supplied for use with standard length work tubes (for use in air) and extended length work tubes (for use with modified atmosphere and vacuum). In vertical work tubes, insulation plug supports are required unless used with work tube end seals (see below).

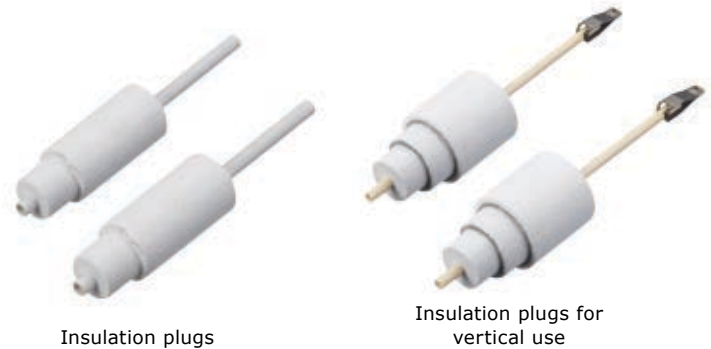

Radiation shields

In extended work tubes radiation shields can be used as an alternative to insulation plugs. Specifically useful for dust free applications and with vacuum levels lower than 10^{-3} mbar. Up to a maximum operating temperature of 1200 °C the shields are constructed from metal, and above this temperature from ceramic. In vertical work tubes, radiation shield supports are required unless used with work tube end seals (see below).

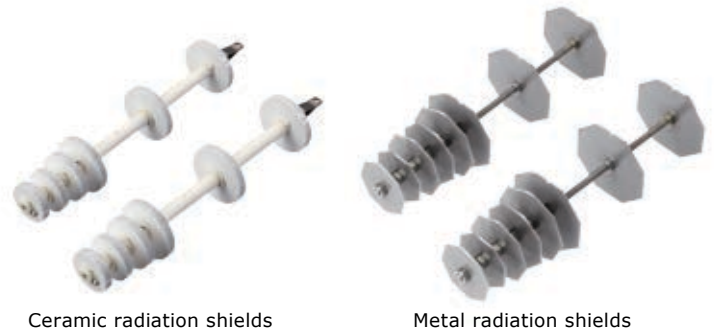

Work tube end seals

Work tube end seals are required to contain a modified atmosphere and for working with vacuum; vacuum levels of 10^{-6} mbar are possible. These end seals are manufactured from stainless steel and are for use with extended work tubes only. They are available to fit work tubes with the following outside diameters: 32, 46, 60, 70, 86, 100, 111, 150 and 165 mm. Other sizes are available at additional cost.



The following fittings are available for use with the end seals: blank seal, gas nozzle (inlet/outlet), vacuum flanges (NW16, NW25 or NW40) and thermocouple glands (ø1.5 mm, 3 mm and 10 mm). Where the end seal diameter is large enough, combinations of the above fittings are possible, eg gas inlet/out nozzle + thermocouple gland. The end seals are designed for use in combination with insulation plugs or radiation shields. Water cooled end seals are available on request. To accommodate the additional weight of end seals, tube supports are recommended (see below).



Tube supports

Tube supports have two functions:

- to support extended work tubes
- to support extended work tubes with the additional weight of end seals



Optional hook and strap tube supports for STF & TZF 1500 & 1600 °C tube furnaces; supplied as standard with the CTF & TZF 1700 and 1800 °C tube furnaces



Optional bench mounted tube supports for furnaces not using hook and strap supports

The following modified atmosphere options are available (must be specified at the time of order).

Inert gas inlet

A 6 mm hose connection is fitted to the product chamber via a tube to create a modified atmosphere. Suitable for the introduction of inert gas or oxygen. Flow rate may be controlled by flow meters – please see below.

NOTE: The introduction of gases may alter heating characteristics and/or performance characteristics of furnace elements, please contact Carbolite for advice.

Gas flow meters

Used to control the flow rate of a gas into the chamber, work tube or retort. A number of flow meters can be fitted for different gases. Suitable for use with argon, carbon dioxide, nitrogen and oxygen – for other gases please enquire. These are fitted to the product on an additional bracket.

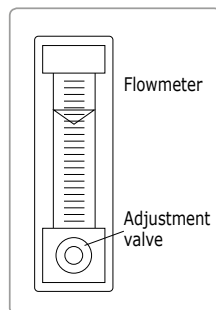

Solenoid valves

Electrically operated valve to control the gas flow into a chamber, work tube or retort. Manually activated by a panel mounted switch or automatically using a temperature programmer. A number of solenoid valves can be fitted for different gases; when used with a temperature programmer the gases can be switched on/off in different program segments (requires 3508 or Nanodac controller).

Atmosphere control system

This system is suitable for use with either tube furnaces using work tube end seals or chamber furnaces using A105 retorts. Housed in its own cabinet, the system is recommended where hydrogen gas is used. It provides greater safety and convenience in control of atmospheres containing more than 5% hydrogen and incorporates a nitrogen purge gas. A monitored burn-off pilot flame ensures exit gases are fully burned. This system monitors the gas pressure, the burn-off flame and the furnace temperature. Failure of any of these results in a safety nitrogen purge. Systems with mass flow control are also available.



Atmosphere retorts

(1100°C maximum temperature) designed to hold a modified atmosphere

Type A105

The Inconel retort is sealed by a removable front opening insulated door. Gas inlet and outlet connections are easily accessible at the front.

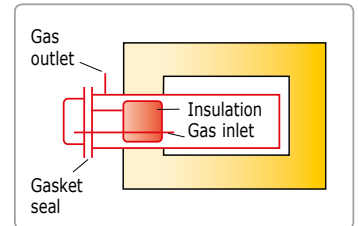

The retort and furnace must be ordered together as the furnace is modified to allow it to be used with, and without, the retort.

Type A107

An Inconel retort with a shallow removable lid locates into a sand seal on top of a deep base. Front mounted gas inlet/outlet connections extend through slots in the furnace door.

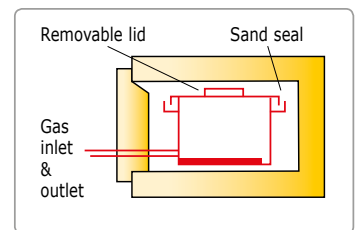

The retort and furnace must be ordered together as the furnace is modified to allow it to be used with, and without, the retort.

Entry ports

Access and viewing ports

A 25 mm diameter hole is positioned in the furnace door and is either fitted with a pivoted stainless steel cover or a permanent quartz window.

Secondary thermocouple

An additional thermocouple is built into the product and connected to a thermocouple socket which is externally mounted on the control panel to enable connection to temperature recorders or other external equipment.

Thermocouple calibration port (for chamber furnaces only)

An additional ceramic thermocouple sheath is installed adjacent to the control thermocouple. This allows the user to insert a reference thermocouple for checking and calibration of the furnace's controller / thermocouple. This is normally located in the rear of the chamber.

The table below provides power supply information for products requiring an electrical supply of more than 16 A single phase. Product not listed here can be used on a 220-240 V single phase 16 A supply.

Model	Volt	Phase	Ampere per phase
AAF /18 litre	220-240	single phase	30
AAF /18 litre	220-240	3 phase delta	18.5
AAF /18 litre	380-415	3 phase + N	10.5
AAF 11/7	240	single phase	17
AAF 11/7	220-230	single phase	16
AAF 11/7	380-415	2 phase + N	8.2
ABA 7/35	220-240	single phase	40
ABA 7/35	220-240	3 phase delta	24
ABA 7/35	380-415	3 phase + N	15
ABF 8/28	220-240	single phase	40
ABF 8/28	220-240	3 phase delta	24
ABF 8/28	380-415	3 phase + N	15
BLF 17/21	380-415	3 phase + N	20
BLF 17/3	200-208	single phase	29
BLF 17/3	220-240	single phase	28
BLF 17/3	380-415	2 phase + N	16.5
BLF 17/8	208	single phase	49
BLF 17/8	208	3 phase delta	29
BLF 17/8	220-240	single phase	46
BLF 17/8	220-240	3 phase delta	27
BLF 17/8	380-415	3 phase + N	15.5
BLF 18/3	208	single phase	26
BLF 18/3	220-240	single phase	25
BLF 18/8	208	3 phase delta	29
BLF 18/8	220-240	3 phase delta	27
BLF 18/8	380-415	3 phase + N	15.5
BWF /13 litre	220-240	single phase	13
BWF /13 litre	380-415	2 phase + N	7.1
CAF Digital	220-240	single phase	49
CAF Digital	380-415	2 phase + N	25
CDHT	380-415	3 phase + N	13
CDLT	380-415	3 phase + N	6.8
CF 24	200	single phase	87
CF 24	440	3 phase no N	30
CF 24	200-240	3 phase delta	50
CF 24	380-415	3 phase + N	28
CF 50	440	3 phase + N	45
CF 50	200-240	3 phase delta	78
CF 50	380-415	3 phase + N	45
CF15	200-240	single phase	68
CF15	200-240	3 phase delta	40
CF15	380-415	3 phase + N	23
CR /330 litre	220-240	single phase	19.5
CR /330 litre	380-415	3 phase + N	8.9
CR /450 litre	220-240	3 phase delta	15.5
CR /450 litre	380-415	3 phase + N	8.9
CR above 450 please enquire			

Model	Volt	Phase	Ampere per phase
CTF 12/100/900	200-240	single phase	21
CTF 12/100/900	220-240	single phase	21
CTF 12/100/900	380-415	2 phase + N	10.5
CTF 17/300	200	single phase	32
CTF 17/300	208	single phase	27
CTF 17/300	220-240	single phase	25
CTF 17/600	200-208	single phase	43
CTF 17/600	220-240	single phase	40
CTF 17/600	380-415	2 phase + N	20
CTF 18/300	200-208	single phase	35
CTF 18/300	220-240	single phase	31
CTF 18/600	200	single phase	43
CTF 18/600	208	single phase	31
CTF 18/600	220-240	single phase	29
CTF 18/600	380-415	3 phase + N	12.5
CTF 18/600	380-415	2 phase + N	19.5
CWF /13 litre	220-240	single phase	13
CWF /13 litre	380-415	2 phase + N	7.1
CWF /23 litre	110-120	single phase	60
CWF /23 litre	200-208	single phase	36
CWF /23 litre	200-208	3 phase delta	22
CWF /23 litre	220-240	single phase	30
CWF /23 litre	220-240	3 phase delta	18.5
CWF /23 litre	380-415	3 phase + N	10.5
CWF /23 litre	380-415	3 phase no N	11
CWF /23 litre	440-480	3 phase no N	10.5
ELF 11/23	200-240	single phase	25
ELF 11/23	380-415	2 phase + N	12.5
GHA, GHC, GVA & GVC 12/1050	220-240	single phase	30
GHA, GHC, GVA & GVC 12/1050	220-240	3 phase delta	18
GHA, GHC, GVA & GVC 12/1050	380-415	3 phase + N	11.5
GHA, GHC, GVA & GVC 12/1200	220-240	single phase	34
GHA, GHC, GVA & GVC 12/1200	220-240	3 phase delta	19.5
GHA, GHC, GVA & GVC 12/1200	380-415	3 phase + N	11.5
GHA, GHC, GVA & GVC 12/600	220-240	single phase	19
GHA, GHC, GVA & GVC 12/600	220-240	3 phase delta	11.5
GHA, GHC, GVA & GVC 12/600	380-415	3 phase + N	7.5
GHA, GHC, GVA & GVC 12/750	220-240	single phase	23

Model	Volt	Phase	Ampere per phase
GHA, GHC, GVA & GVC 12/750	220-240	3 phase delta	15
GHA, GHC, GVA & GVC 12/750	380-415	3 phase + N	9.4
GHA, GHC, GVA & GVC 12/900	220-240	single phase	27
GHA, GHC, GVA & GVC 12/900	220-240	3 phase delta	16.5
GHA, GHC, GVA & GVC 12/900	380-415	3 phase + N	9.4
GP330	220-240	single phase	19.5
GP330	220-240	3 phase delta	12
GP330	380-415	3 phase + N	7
GP450	220-240	single phase	26
GP450	220-240	3 phase delta	15
GP450	380-415	3 phase + N	12.5
GPC 12/200	240	3 phase delta	58
GPC 12/200	415	3 phase + N	34
GPC 12/200	220-230	3 phase delta	64
GPC 12/200	380-400	3 phase + N	37
GPC /36 litre	220-240	single phase	44
GPC /36 litre	220-240	3 phase delta	26
GPC /36 litre	380-415	3 phase + N	15
GPC /65 litre	220-240	single phase	63
GPC /65 litre	220-240	3 phase delta	37
GPC /65 litre	380-415	3 phase + N	21
GPC 12/131	220	3 phase delta	42
GPC 12/131	380-415	3 phase + N	26
GPC 13/131	220-240	3 phase delta	50
GPC 13/131	380-415	3 phase + N	29
HRF 7/112	220-240	3 phase delta	44
HRF 7/112	380-415	3 phase + N	26
HRF 7/324	380-415	3 phase + N	34
HRF 7/45	220-240	single phase	26
HRF 7/45	220-240	3 phase delta	15.5
HRF 7/45	380-415	3 phase + N	9
HST 12/900	200-240	3 phase delta	15
HST 12/900	220-240	single phase	22
HST 12/900	380-415	3 phase + N	8.4
HT, HTCR, HTMA 5/220	220-240	single phase	19.5
HT, HTCR, HTMA 5/220	380-415	2 phase + N	10
HT, HTCR, HTMA 6/220	220-240	single phase	26
HT, HTCR, HTMA 6/220	220-240	3 phase delta	15
HT, HTCR, HTMA 6/220	380-415	3 phase + N	12.5

Model	Volt	Phase	Ampere per phase
HT, HTCR, HTMA 6/95	220-240	single phase	19.5
HT, HTCR, HTMA 6/95	380-415	2 phase + N	10
HT, HTCR, HTMA above 220 litre please enquire			
HTF 17/10	220-240	single phase	28
HTF 17/10	380-415	2 phase + N	16
HTF 18/15	208	single phase	46
HTF 18/15	220-240	single phase	43
HTF 18/15	380-415	3 phase + N	16
HTF 18/27	208	3 phase delta	48
HTF 18/27	440	3 phase delta	23
HTF 18/27	480	3 phase delta	21
HTF 18/27	220-240	3 phase delta	45
HTF 18/27	380-415	3 phase + N	26
HTF 18/4	220-240	single phase	21
HTF 18/4	380-415	2 phase + N	16
HTF 18/8	220-240	single phase	30
HTF 18/8	380-415	2 phase + N	16
HVTT 12/60/700	220-240	single phase	18.5
HVTT 12/80/700	220-240	single phase	21
HVTT 15/50/450	220-240	single phase	45
HVTT 15/50/450	380-415	2 phase + N	26
HVTT 15/75/450	220-240	single phase	45
HVTT 15/75/450	380-415	2 phase + N	26
HZS 12/900	200-240	3 phase delta	15
HZS 12/900	220-240	single phase	22
HZS 12/900	380-415	3 phase + N	8.4
LCF - please enquire			
LGP - please enquire			
RHF 14/15	200-240	single phase	62
RHF 14/15	200-240	3 phase delta	38
RHF 14/15	380-415	3 phase + N	22
RHF 14/3	200-240	single phase	22
RHF 14/3	380-415	2 phase + N	15
RHF 14/35	200-240	3 phase delta	60
RHF 14/35	380-415	3 phase + N	35
RHF 14/35	440-480	3 phase no N	35
RHF 14/8	200-240	single phase	50
RHF 14/8	380-415	2 phase + N	25

Model	Volt	Phase	Ampere per phase
RHF 15/15	200-240	single phase	75
RHF 15/15	200-240	3 phase delta	43
RHF 15/15	380-415	3 phase + N	25
RHF 15/3	200-240	single phase	36
RHF 15/3	380-415	2 phase + N	18
RHF 15/35	200-240	3 phase delta	60
RHF 15/35	380-415	3 phase + N	35
RHF 15/35	380-415	3 phase no N	35
RHF 15/35	440-480	3 phase no N	35
RHF 15/8	200-208	3 phase delta	38
RHF 15/8	200-240	single phase	50
RHF 15/8	200-240	3 phase delta	30
RHF 15/8	380-415	3 phase + N	17.5
RHF 15/8	380-415	3 phase no N	17.5
RHF 16/15	200-240	single phase	73
RHF 16/15	200-240	3 phase delta	42
RHF 16/15	380-415	3 phase + N	25
RHF 16/15	440-480	3 phase + N	25
RHF 16/3	200-240	single phase	36
RHF 16/3	200-240	3 phase delta	30
RHF 16/3	380-415	2 phase + N	18
RHF 16/35	200-240	3 phase delta	62
RHF 16/35	380-415	3 phase + N	40
RHF 16/35	380-415	3 phase no N	37
RHF 16/35	440-480	3 phase + N	40
RHF 16/8	200-208	3 phase delta	34
RHF 16/8	200-240	single phase	59
RHF 16/8	220-240	single phase	50
RHF 16/8	220-240	3 phase delta	29
RHF 16/8	380-415	3 phase + N	18
RHF 16/8	380-415	3 phase no N	18
RHF 16/8	440-480	3 phase + N	18
RHF 17/25	208	3 phase delta	30
RHF 17/25	440	3 phase delta	12.5
RHF 17/25	220-240	single phase	48
RHF 17/25	220-240	3 phase delta	28
RHF 17/25	380-415	3 phase + N	16
RWF /13 litre	220-240	single phase	22
RWF /13 litre	380-415	2 phase + N	11
RWF /23 litre	220-240	single phase	39
RWF /23 litre	220-240	3 phase delta	23
RWF /23 litre	380-415	3 phase + N	13
SCF - please enquire			
STF 15/180	110-120	single phase	24
STF 15/180	200-240	single phase	12
STF 15/450	208	3 phase + N	25
STF 15/450	200-240	single phase	39
STF 15/450	380-415	2 phase + N	19.5
STF 15/610	200-208	single phase	44

Model	Volt	Phase	Ampere per phase
STF 15/610	200-240	3 phase delta	34
STF 15/610	220-240	single phase	32
STF 15/610	220-240	3 phase + N	19.5
STF 15/610	380-415	2 phase + N	19.5
STF 16/180	200-240	single phase	23
STF 16/450	200-240	single phase	47
STF 16/450	200-240	3 phase delta	39
STF 16/450	380-415	2 phase + N	24
STF 16/450	380-415	3 phase + N	21
STF 16/450	380-415	3 phase no N	21
STF 16/610	380	3 phase + N	25
STF 16/610	200-220	3 phase delta	43
STF 16/610	200-240	single phase	50
STF 16/610	230-240	3 phase delta	46
STF 16/610	380-415	2 phase + N	25
STF 16/610	400-415	3 phase + N	27
TVS 12/900	200-240	3 phase delta	15
TVS 12/900	220-240	single phase	22
TVS 12/900	380-415	3 phase + N	8.4
TZF 12/100/900	220-240	single phase	19.5
TZF 12/100/900	380-415	3 phase + N	8.4
TZF 15/610	200-240	single phase	60
TZF 15/610	220-240	3 phase delta	38
TZF 15/610	380-415	3 phase + N	22
TZF 16/610	220-240	single phase	62
TZF 16/610	220-240	3 phase delta	40
TZF 16/610	380-415	3 phase + N	25
TZF 17/600	208	single phase	48
TZF 17/600	220-240	single phase	46
TZF 17/600	220-240	3 phase delta	34
TZF 17/600	380-415	3 phase + N	28
TZF 18/600	208	3 phase delta	30
TZF 18/600	220-240	single phase	40
TZF 18/600	220-240	3 phase delta	28
TZF 18/600	380-415	3 phase + N	24
VCF 12/100	220-240	single phase	69
VCF 12/100	220-240	3 phase delta	40
VCF 12/100	380-415	3 phase + N	23
VCF 12/23	220-240	single phase	25
VCF 12/23	380-415	3 phase + N	11.5
VST 12/900	200-240	3 phase delta	15
VST 12/900	220-240	single phase	22
VST 12/900	380-415	3 phase + N	8.4
VST 17/--/250	200-208	single phase	25
VST 17/--/250	220-240	single phase	22

Model	Description	Page
A		
AAF	Standard Ashing Furnaces	34
ABA	Asphalt Binder Analyser	16
ABF	Afterburner Ashing Furnace	37
AX	Laboratory Bench Mounted Ovens	10
B		
BLF	High Temperature Bottom Loading Furnaces	67
BWF	Burn-off Furnaces	36
C		
CDF	Dental Furnace	74
CF	Cupellation Furnaces	59
CR	Clean Room Ovens to 250°C	19
CTF	Large Tube Furnaces (1200°C)	41
CTF	High Temperature Horizontal Tube Furnaces (1700°C)	71
CTF	High Temperature Horizontal Tube Furnaces (1800°C)	71
CUF	Standard Chamber Furnaces	31
E		
EHA	Compact Modular Tube Furnaces	42
EHC	Compact Modular 3-Zone Tube Furnaces	50
ELF	Economy Chamber Furnaces	30
EST	Compact Modular Tube Furnaces	42
EVA	Compact Modular Tube Furnaces	42
EVC	Compact Modular 3-Zone Tube Furnaces	50
EVT	Compact Modular Tube Furnaces	42
EVZ	Compact Modular 3-Zone Tube Furnaces	50
EZS	Compact Modular 3-Zone Tube Furnaces	50
G		
GHA	Modular Horizontal Tube Furnaces	46
GHC	Modular Horizontal 3-Zone Tube Furnaces	54
GP	General Purpose Ovens	23
GPC	General Purpose Chamber Furnaces	60
GSM	Specialist Ashing Furnace	35
GVA	Modular Vertical Tube Furnaces	47
GVC	Modular Vertical 3-Zone Tube Furnaces	55

Model	Description	Page
H		
HRF	Air Recirculating Ovens	22
HST	Horizontal Split Tube Furnaces	44
HT	High Temperature Industrial Ovens	14
HTCR	High Temperature Clean Room Ovens	20
HTF	High Temperature Laboratory Chamber Furnaces	66
HTMA	Modified Atmosphere Ovens	15
HTR	Rotary Reactor Tube Furnaces	48
HVTT	High Vacuum Tube Furnaces (1200°C)	57
HVTT	High Vacuum Tube Furnaces (1500°C)	73
HZS	Horizontal Split 3-Zone Tube Furnaces	52
L		
LCF	Large Chamber Furnaces	61
LGP	Large General Purpose Ovens	24
LHT	High Temperature Bench Mounted Ovens	13
M		
MTF	Small Tube Furnaces	40
MTT	Carbon-14 and Tritium Furnaces	56
P		
PF	Fan Convection Ovens	12
PN	Natural Convection Ovens	11
PTC	Thermocouple Calibration Furnaces	58
R		
RHF	High Temperature Chamber Furnaces	64
RWF	Rapid Heating Chamber Furnaces	32
S		
SCF	Smelting Furnaces	75
STF	High Temperature Single Zone Tube Furnaces	68
T		
TLD	Rapid Cooling Ovens	18
TVS	Vertical Split 3-Zone Tube Furnaces	53
TZF	Standard 3-Zone Tube Furnaces (1200°C)	49
TZF	Standard 3-Zone Tube Furnaces (1500°C)	72
TZF	High Temperature 3-Zone Tube Furnaces (1600°C)	72
TZF	High Temperature 3-Zone Tube Furnaces (1700°C)	72
TZF	High Temperature 3-Zone Tube Furnaces (1800°C)	72
V		
VCF	Top Loading Chamber Furnaces	33
VST	Vertical Split Tube Furnaces (1200°C)	45
VST	High Temperature Vertical Single Zone Split Tube Furnaces (1700°C)	70

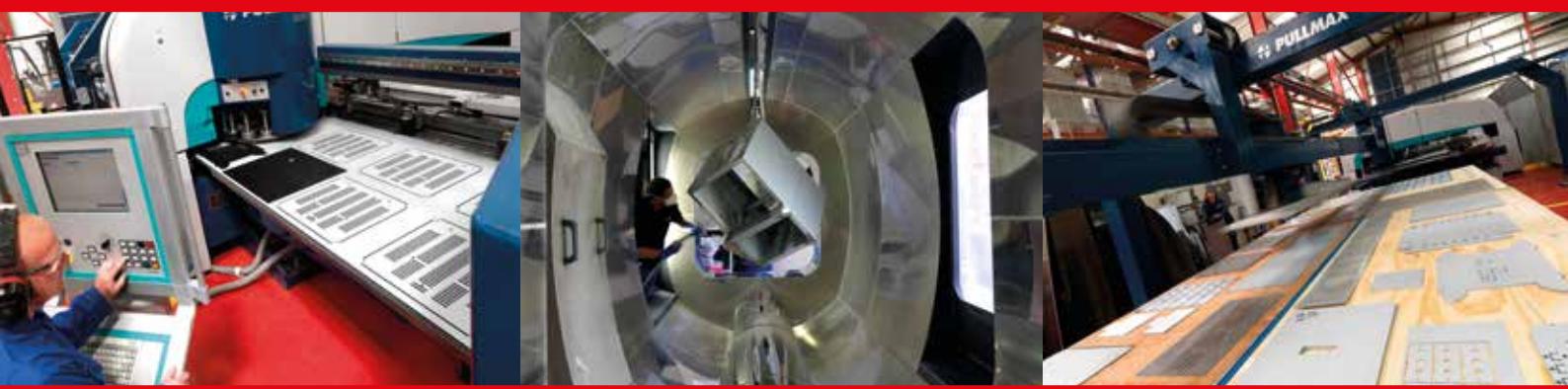

CARBOLITE®

Leading Heat Technology

CARBOLITE®
Leading Heat Technology



Carbolite Ltd.
Parsons Lane, Hope
Hope Valley, S33 6RB
UK

Phone +44 (0) 1433 620011
Fax +44 (0) 1433 621198
E-Mail info@carbolite.com
Internet www.carbolite.com

part of **VERDER**
scientific

